

7008 Northland Drive
Suite 150
Minneapolis, MN 55428
(800) 337-5339 | (763) 533-2094
Fax: (763) 533-2096

Project name: Trex Panel Rail – Aluminum and Mesh Railing System (Residential)	
Creation date: 4/10/19	
Last revision: 5/29/19	
Revision: 2	

I hereby certify that the following pages of this report were prepared by me or under my direct supervision and that I am a duly Licensed Professional Engineer under the laws of the states shown on the following pages.



Anthony J Barnes, PE

5/29/19



COMMERCIAL
PRODUCTS

7008 Northland Drive
Suite 150
Minneapolis, MN 55428
(800) 337-5339 | (763) 533-2094
Fax: (763) 533-2096

State	Expiration	License #
Alabama	12/31/2019	34664
Arizona	6/30/2020	63922
Arkansas	12/31/2019	18157
California	9/30/2019	84471
Colorado	10/31/2019	PE.0049211
Connecticut	1/31/2020	PEN.0032950
Florida	2/28/2021	77515
Georgia	12/31/2020	PE039214
Idaho	9/30/2020	P-17222
Indiana	7/31/2020	PE11400345
Iowa	12/31/2019	22527
Kansas	4/30/2020	PE26251
Kentucky	6/30/2019	33339
Louisiana	9/30/2020	39025
Maryland	8/7/2020	45817
Massachusetts	6/30/2020	51462
Michigan	10/31/2020	6201063081
Minnesota	6/30/2020	51612
Mississippi	12/31/2019	26806
Missouri	12/31/2020	PE2014023010
Montana	6/30/2020	60121
Nebraska	12/31/2019	E-15134
Nevada	12/31/2020	023009
New Hampshire	9/30/2019	15604
New Jersey	4/30/2020	24GE05291300
New Mexico	12/31/2019	24093
New York	8/31/2019	094109
North Carolina	12/31/2019	041703
North Dakota	12/31/2020	PE-9715
Ohio	12/31/2019	79131
Oklahoma	8/31/2019	27838
Oregon	12/31/2019	93346PE
Pennsylvania	9/30/2019	PE082756
Rhode Island	6/30/2019	12533
South Carolina	6/30/2020	33939
South Dakota	7/31/2020	13915
Tennessee	8/31/2020	00117639
Texas	6/30/2019	PE 117821
Utah	3/31/2021	9163877-2202
Virginia	10/31/2020	402054114
Washington	9/15/2019	51729
Washington, DC	8/31/2020	PE907658
West Virginia	12/31/2020	23467
Wisconsin	7/31/2020	43059-6
Wyoming	12/31/2019	16000



COMMERCIAL
PRODUCTS

7008 Northland Drive
Suite 150
Minneapolis, MN 55428
(800) 337-5339 | (763) 533-2094
Fax: (763) 533-2096

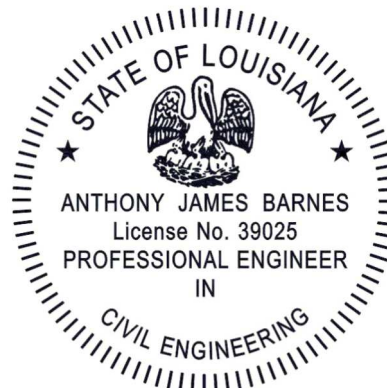
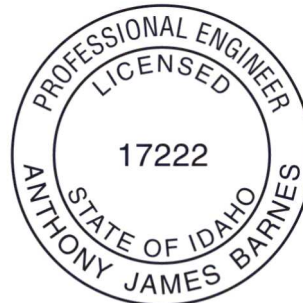



COMMERCIAL
PRODUCTS

7008 Northland Drive
Suite 150
Minneapolis, MN 55428
(800) 337-5339 | (763) 533-2094
Fax: (763) 533-2096

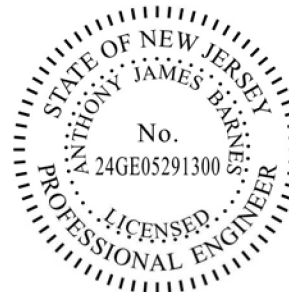
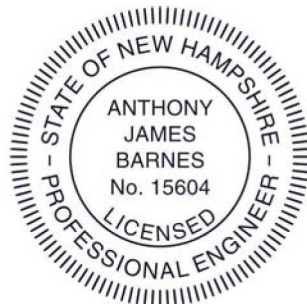
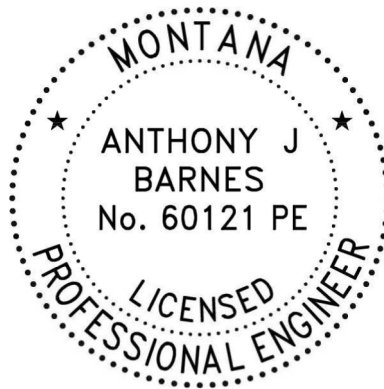



COMMERCIAL PRODUCTS

7008 Northland Drive
Suite 150
Minneapolis, MN 55428
(800) 337-5339 | (763) 533-2094
Fax: (763) 533-2096



EXPIRES: 12/31/19

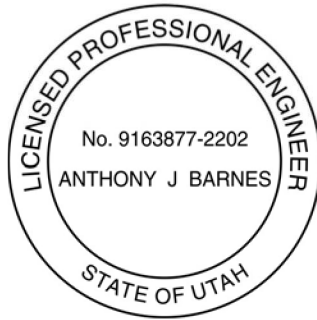
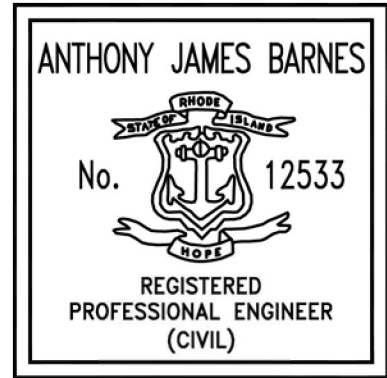

7008 Northland Drive
Suite 150
Minneapolis, MN 55428
(800) 337-5339 | (763) 533-2094
Fax: (763) 533-2096









COMMERCIAL
PRODUCTS

7008 Northland Drive
Suite 150
Minneapolis, MN 55428
(800) 337-5339 | (763) 533-2094
Fax: (763) 533-2096

Contents

1	Description	9
2	Design Criteria.....	9
2.1	Building codes/standards/project specifications.....	9
2.2	Design loads	9
2.2.1	Live load.....	9
2.2.2	Wind load	9
2.3	Deflections	10
2.4	 Material used	11
2.4.1	Aluminum buckling constants.....	11
3	Mesh infill	12
4	Railing check.....	14
4.1	 Post, weld, and base plate test results	14
4.1.1	 Allowable load for 2-1/2" x 2-1/2" Welded 6063-T6 (Trex)	14
4.2	Anchorage check.....	16
4.2.1	 Lag screw check	16
4.2.2	Through-bolts with backer.....	17
4.3	Top rail and bottom rail check.....	18
4.3.1	Top rail	18
4.3.2	Bottom rail	24
4.3.3	 L-bracket	27
4.3.4	Test results.....	28
5	Conclusion.....	30
6	Appendix A – aluminum tensile test results	31
6.1	Description.....	31
6.2	Results.....	33



COMMERCIAL
PRODUCTS

**7008 Northland Drive
Suite 150
Minneapolis, MN 55428
(800) 337-5339 | (763) 533-2094
Fax: (763) 533-2096**

6.3	Derived properties	37
6.4	Conclusions and applicability of data	38



COMMERCIAL
PRODUCTS

7008 Northland Drive
Suite 150
Minneapolis, MN 55428
(800) 337-5339 | (763) 533-2094
Fax: (763) 533-2096

Revision	Description
1	1) Revised material alloy of post in section 2.4 to those used in testing. Updated base plate temper and alloy to those used in testing. 2) Revised weld detail in section 4.1.1 3) Added L-bracket section
2	1) Removed lag screw check

1 Description

This calculation covers the Trex aluminum railing system with mesh infill. The railing is constructed of aluminum posts, top rail, and a bottom rail that secures the mesh in place. Railing height is 36"-42" with maximum inside to inside post spacing of 96".

2 Design Criteria

2.1 Building codes/standards/project specifications

- 1) IRC 2015
- 2) Aluminum Design Manual 2015
- 3) AAMA TIR A9
- 4) AISC 360-10
- 5) NDS 2018
- 6) ACI 318-14

2.2 Design loads

2.2.1 Live load

Design Criteria	Requirement
Guard/handrail live loads	200 lbf applied at any point at the top of the rail per IRC 301.5, OR 50 lbf over 1 sf area per IRC table R301.5 sub note f.

2.2.2 Wind load

The system is considered open and wind loads do not control over live loads.



COMMERCIAL
PRODUCTS

7008 Northland Drive
Suite 150
Minneapolis, MN 55428
(800) 337-5339 | (763) 533-2094
Fax: (763) 533-2096

2.3 Deflections

Deflection	<u>Aluminum, steel, stainless steel:</u> $L/60$ per minimum requirements of IBC table R301.7 sub note c where $L = 2 \cdot \text{Length}$ for cantilevers
------------	---

$$I := 1.119 \cdot \text{in}^4$$

$$E := 10100 \cdot \text{ksi}$$

$$L := 42 \cdot \text{in}$$

$$P := \frac{13.649 \cdot \text{kip} \cdot \text{in}}{L} = 325 \text{ lbf}$$

$$\Delta := \frac{P \cdot L^3}{3 \cdot E \cdot I} = 0.71 \text{ in}$$

$42 \text{ in} / 30 = 1.4 \text{ in}$ (allowable deflection) $> 0.71 \text{ in}$ deflection on post

The allowable moment on the post is 13.649 k-in. See section 4.1.2 for more information.



COMMERCIAL
PRODUCTS

7008 Northland Drive
Suite 150
Minneapolis, MN 55428
(800) 337-5339 | (763) 533-2094
Fax: (763) 533-2096

2.4 ¹ Material used

Component	Material	Yield	Ultimate
Top rail	Aluminum 6063-T6	25 ksi	30 ksi
Bottom extrusion	Aluminum 6063-T6	25 ksi	30 ksi
Posts	Aluminum 6061-T6	25 ksi (8 ksi)	30 ksi (17 ksi)
Baseplates	Aluminum 6063-T6	25 ksi	30 ksi
Screws	Stainless steel	30 ksi	70 ksi
Mesh	Stainless steel (steel)	30 ksi	70 ksi

*Welded properties in parentheses

** Equivalent alloy and temper may be used for aluminum extrusions

2.4.1 Aluminum buckling constants

Buckling constants for T5-T9 tempers

Non welded:



COMMERCIAL
PRODUCTS

7008 Northland Drive
Suite 150
Minneapolis, MN 55428
(800) 337-5339 | (763) 533-2094
Fax: (763) 533-2096

Aluminum Design (ADM 2015)

Alloy = 6061

Temper = "T6"

Description = "Native ADM"

Material Properties (Table A.3.3)

E = 10100-ksi

G := 3800-ksi

F_{tu} = 38-ksi

F_{ty} = 35-ksi

F_{cy} = 35-ksi

F_{sy} = 21-ksi

F_{su} = 22.8-ksi

Buckling Constants (Table B.4.1/B.4.2)

B_c = 39.4-ksi

B_p = 45-ksi

B_{br} = 66.8-ksi

B_s = 27.2-ksi

B_t = 43.2-ksi

B_{tb} = 64.8-ksi

D_c = 0.246-ksi

D_p = 0.3-ksi

D_{br} = 0.666-ksi

D_s = 0.141-ksi

D_t = 1.558-ksi

D_{tb} = 4.5-ksi

C_c = 65.7

C_p = 61.4

C_{br} = 66.9

C_s = 78.9

C_{tb} = 55.44

Postbuckling Constants (Table B.4.3)

k_{1_f} = 0.5

k_{2_f} = 2.04

k_{1_c} = 0.35

k_{2_c} = 2.27

Tension Coefficient (Table A.3.3)

k_t = 1

Welded:

Aluminum Design (ADM 2015)

Alloy = 6061

Temper = "T6"

Description = "Welded**"

Material Properties (Table A.3.3)

E = 10100-ksi

G := 3800-ksi

F_{tu} = 29.1-ksi

F_{ty} = 21.6-ksi

F_{cy} = 21.6-ksi

F_{sy} = 13-ksi

F_{su} = 17.46-ksi

Buckling Constants (Table B.4.1/B.4.2)

B_c = 23.7-ksi

B_p = 26.9-ksi

B_{br} = 39.3-ksi

B_s = 16.2-ksi

B_t = 26.2-ksi

B_{tb} = 39.3-ksi

D_c = 0.115-ksi

D_p = 0.138-ksi

D_{br} = 0.3-ksi

D_s = 0.065-ksi

D_t = 0.799-ksi

D_{tb} = 2.3-ksi

C_c = 84.6

C_p = 79.5

C_{br} = 87.3

C_s = 102.2

C_{tb} = 77.386

Postbuckling Constants (Table B.4.3)

k_{1_f} = 0.5

k_{2_f} = 2.04

k_{1_c} = 0.35

k_{2_c} = 2.27

Tension Coefficient (Table A.3.3)

k_t = 1

Note, these buckling constants will be used in calculating the capacity of the post and the extrusions holding the glass.

3 Mesh infill

Typical panel make-up:



COMMERCIAL
PRODUCTS

7008 Northland Drive
Suite 150
Minneapolis, MN 55428
(800) 337-5339 | (763) 533-2094
Fax: (763) 533-2096

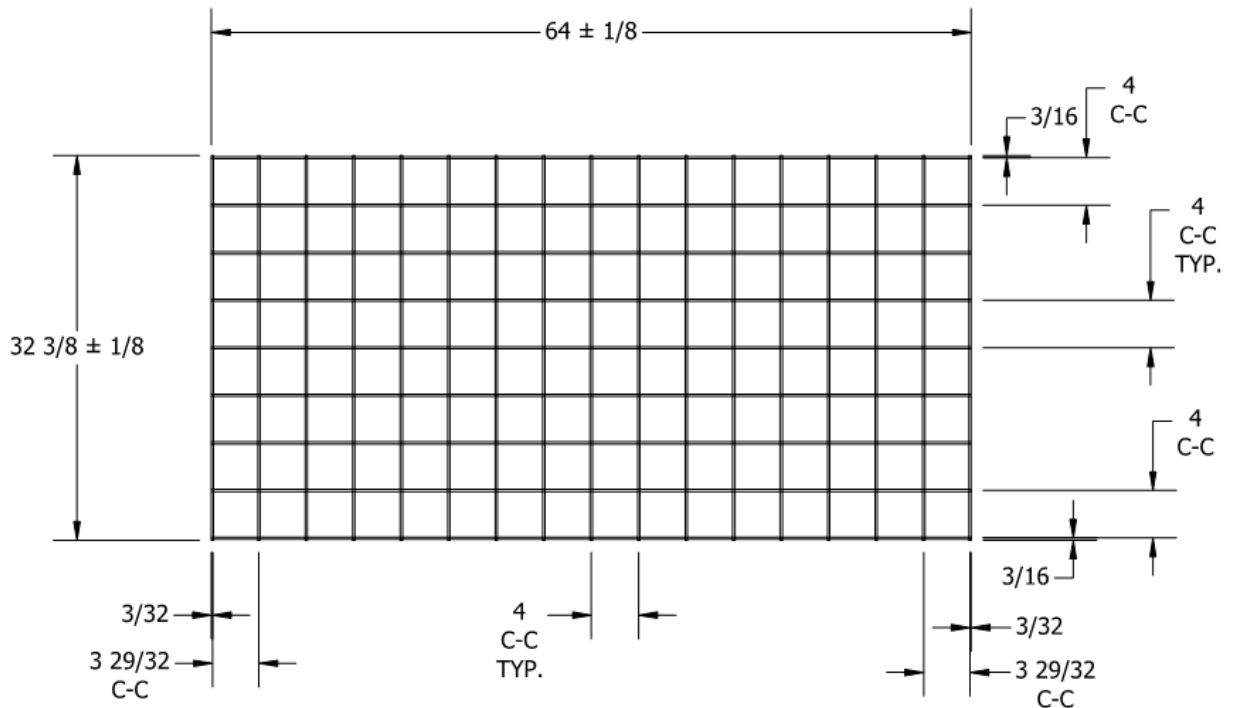

NOTES:

- GALVANIZED OR 316 STAINLESS STEEL WELDED WIRE MESH
- WIRE SIZE = $\varnothing 0.188$ " ($\varnothing 0.187$ " NOM. FOR GALVANIZED AND $\varnothing 0.192$ " NOM. FOR 316 STAINLESS)
- C-C SPACING = 4.000" TYP.

50 lbs infill load is required to be applied over 1 square foot of the mesh. The mesh is 3/16" wire that is either stainless steel or steel.

Mesh and attachments of the mesh are adequate by inspection due to the small loading.



COMMERCIAL
PRODUCTS

7008 Northland Drive
Suite 150
Minneapolis, MN 55428
(800) 337-5339 | (763) 533-2094
Fax: (763) 533-2096

4 Railing check

4.1 1 Post, weld, and base plate test results

4.1.1 1 Allowable load for 2-1/2" x 2-1/2" Welded 6063-T6 (Trex)

This covers the post used by Trex in their Signature (IRC) residential railing. This post has a 4"x4" baseplate welded to it. The post/baseplate assembly is tested as a single unit.

NOTES:

1. APPLICABLE STANDARDS AND SPECIFICATIONS ASME Y14.5 2009 DIMENSIONS AND TOLERANCE.
2. MATERIAL: MAKE FROM 990000106700 IRC POST EXTRUSION
3. BREAK ALL EDGES AND CORNERS 0.01 MAX.

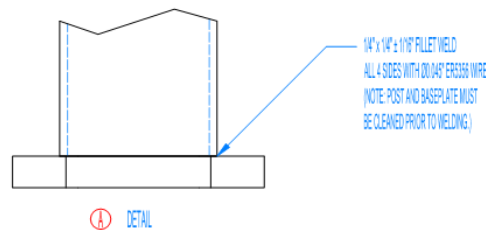
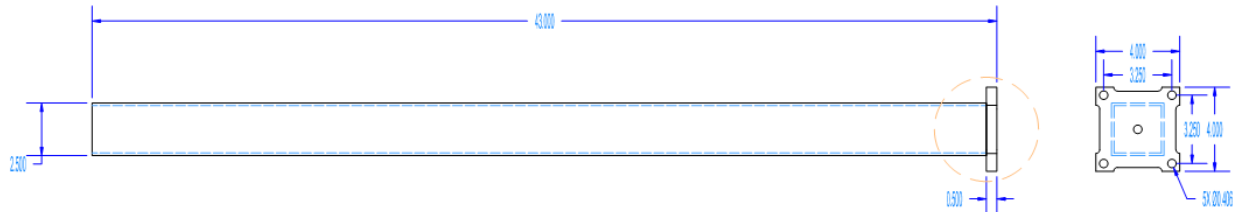

All material for post is 6063-T6 with ER5356 wire for welding

Data was taken from the Trex assembly line's daily tests, which consists of ultimate loads on samples taken from the production line.

Applied live load = 0.2 k * 43 in = 8.6 k-in



COMMERCIAL
PRODUCTS

7008 Northland Drive
Suite 150
Minneapolis, MN 55428
(800) 337-5339 | (763) 533-2094
Fax: (763) 533-2096

Sample Number	Ultimate Load (lbf)	Average load	Standard deviation	Min.	kN, 5%	COV	Strength (lbs)	FOS
Based on 4/23/18 tests in Winchester, VA								
1	625	635.1875	14.4	610	1.92	0.0226	607.6	3.04
2	621							
3	610							
4	636							
5	647							
6	632							
7	633							
8	624							
9	651							
10	659							
11	633							
12	644							
13	623							
14	652							
15	653							
16	620							

*Derived per methods of EN 1990-2002, Appendix D, Table D1

607.6 lb / 2.5 FS = 243 lb maximum applied load > 200 lb code specified **OK**
 243 lb / 50 lb/ft = 4.86' = 58" maximum post spacing > 48" maximum used **OK**

Deflection:

$$\text{Limit} = 2*L/60 = 2*42.5"/60 = 1.42"$$

$$\Delta = \frac{PL^3}{3EI} = \frac{(0.2 k)(42.5")^3}{3(10100 ksi)(1.12 in^4)} = 0.45" < 1.42" \text{ limit } \mathbf{OK}$$

Table 23
SQUARE TUBES

Designation	d in.	t in.	Weight lb/ft	A in ²	I _x , I _y in ⁴	S _x , S _y in ³	r _x , r _y in.	J in ⁴	Z _x , Z _y in ³	b/t
RT 2.5 x 2.5 x 0.125	2.5	0.125	1.4	1.19	1.12	0.896	0.971	1.67	1.06	18

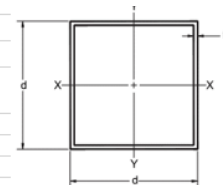

- NOTES:
 1. APPLICABLE STANDARDS AND SPECIFICATIONS ASME Y14.5 2009 DIMENSIONS AND TOLERANCE.
 2. MATERIAL: MAKE FROM 990000106700 IRC POST EXTRUSION
 3. BREAK ALL EDGES AND CORNERS 0.01 MAX.

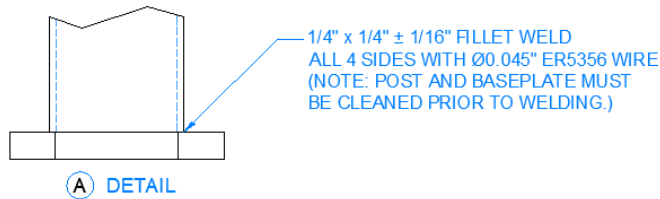
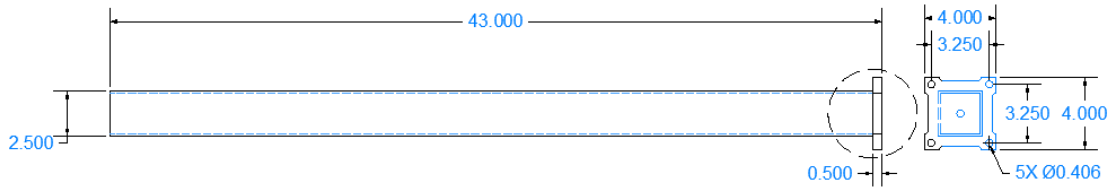

Allowable moment = 243 lbs * 43 in = 10.45 k-in

4.2 Anchorage check

4.2.1 2 Lag screw check

Section removed



COMMERCIAL
PRODUCTS

7008 Northland Drive
Suite 150
Minneapolis, MN 55428
(800) 337-5339 | (763) 533-2094
Fax: (763) 533-2096

4.2.2 Through-bolts with backer

Reference Code Compliance Research Report CCRR-0202 for connection details.

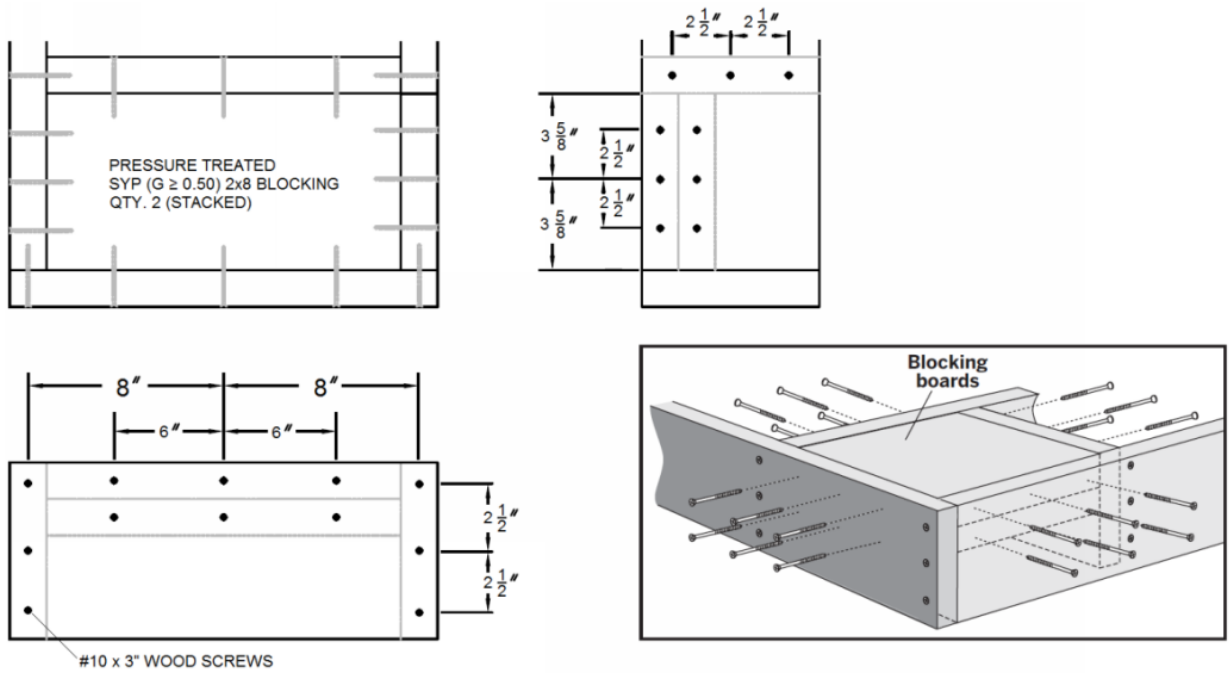

Wood blocking detail

Figure 9 – Post Mount Installation on Wood Deck



COMMERCIAL
PRODUCTS

7008 Northland Drive
Suite 150
Minneapolis, MN 55428
(800) 337-5339 | (763) 533-2094
Fax: (763) 533-2096

4.3 Top rail and bottom rail check

4.3.1 Top rail

Loading on top rail due to live load:

(93.5" inside of post to inside of post)

$$M_x = \frac{PL}{4} = \frac{0.2 k * 93.5 in}{4} = 4.6 kip - in$$

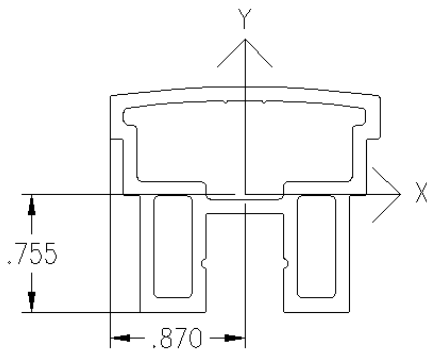

----- REGIONS -----			
Area:	0.7113		
Perimeter:	15.2292		
Bounding box:	X: -0.8700	--	0.8700
Y:	-0.7553	--	0.6967
Centroid:	X: 0.0000		
Y:	0.0000		
Moments of inertia:	X: 0.1497		
Y:	0.2030		
Product of inertia:	XY: 0.0000		
Radii of gyration:	X: 0.4588		
Y:	0.5342		
Principal moments and X-Y directions about centroid:			
I:	0.1497	along	[1.0000 0.0000]
J:	0.2030	along	[0.0000 1.0000]
Zy	= 0.346	IN ³	
Zx	= 0.273	IN ³	



COMMERCIAL
PRODUCTS

7008 Northland Drive
Suite 150
Minneapolis, MN 55428
(800) 337-5339 | (763) 533-2094
Fax: (763) 533-2096

4.3.1.1 Vertical moment capacity

Custom extrusion design per ADM 2015

Properties

6063-T6

$$F_{ty} := 25 \cdot \text{ksi}$$

$$E := 10100 \cdot \text{ksi}$$

$$k_1 := 0.35$$

$$F_u := 30 \cdot \text{ksi}$$

$$G := 3800 \cdot \text{ksi}$$

$$k_2 := 2.27$$

$$F_{cy} := 25 \cdot \text{ksi}$$

$$L_b := 96 \cdot \text{in}$$

$$F_{su} := 0.6 \cdot F_u = 18 \cdot \text{ksi}$$

$$K := 1.0$$

$$F_{sy} := 0.6 \cdot F_{ty} = 15 \cdot \text{ksi}$$

$$k_t := 1.0$$

$$C_b := 1.0 \quad \text{conservatively can be left as 1.0}$$

Section properties

$$c_c := 0.755 \cdot \text{in} \quad \text{compression side}$$

$$I_x := 0.1497 \cdot \text{in}^4$$

$$Z_x := 0.346 \cdot \text{in}^3$$

$$c_o := 0.697 \cdot \text{in}$$

$$I_y := 0.203 \cdot \text{in}^4$$

$$A_g := 0.7113 \cdot \text{in}^2$$

$$Z_y := 0.273 \cdot \text{in}^3$$

$$S_x := \frac{I_x}{c_c} = 0.198 \cdot \text{in}^3$$

$$r_x := \sqrt{\frac{I_x}{A_g}} = 0.459 \cdot \text{in}$$

$$S_y := \frac{I_y}{c_o} = 0.291 \cdot \text{in}^3$$

$$r_y := \sqrt{\frac{I_y}{A_g}} = 0.534 \cdot \text{in}$$

Resistance and safety Factors

$$\Omega := 1.65$$

$$\Omega_r := 1.95$$



COMMERCIAL
PRODUCTS

7008 Northland Drive
Suite 150
Minneapolis, MN 55428
(800) 337-5339 | (763) 533-2094
Fax: (763) 533-2096

Design of Members for Flexure Chapter F

Check yielding and rupture - section F.2

Yielding

$$Z_x \cdot F_{cy} = 8.65 \cdot \text{kip-in} \quad 1.5 \cdot S_x \cdot F_{cy} = 7.435 \cdot \text{kip-in} \quad k_t := 1.0 \quad \text{Dependent on type of Aluminum}$$

$$M_{nux} := \begin{cases} Z_x \cdot F_{cy} & \text{if } Z_x \cdot F_{cy} \leq 1.5 \cdot S_x \cdot F_{cy} \\ 1.5 \cdot S_x \cdot F_{cy} & \text{if } 1.5 \cdot S_x \cdot F_{cy} < Z_x \cdot F_{cy} \end{cases} = 7.435 \cdot \text{kip-in}$$

$$M_1 := \frac{M_{nux}}{\Omega} = 4.506 \cdot \text{kip-in} \quad \text{YIELDING}$$

Rupture

$$M_{nux} := \frac{Z_x \cdot F_u}{k_t} = 10.38 \cdot \text{kip-in}$$

$$M_2 := \frac{M_{nux}}{\Omega_r} = 5.323 \cdot \text{kip-in} \quad \text{RUPTURE}$$

Yielding

$$Z_y \cdot F_{cy} = 6.825 \cdot \text{kip-in} \quad 1.5 \cdot S_y \cdot F_{cy} = 10.922 \cdot \text{kip-in} \quad k_t := 1.0 \quad \text{Dependent on type of Aluminum}$$

$$M_{nuy} := \begin{cases} Z_y \cdot F_{cy} & \text{if } Z_y \cdot F_{cy} \leq 1.5 \cdot S_y \cdot F_{cy} \\ 1.5 \cdot S_y \cdot F_{cy} & \text{if } 1.5 \cdot S_y \cdot F_{cy} < Z_y \cdot F_{cy} \end{cases} = 6.825 \cdot \text{kip-in}$$

$$M_3 := \frac{M_{nuy}}{\Omega} = 4.136 \cdot \text{kip-in} \quad \text{YIELDING}$$

Rupture

$$M_{nuy} := \frac{Z_y \cdot F_u}{k_t} = 8.19 \cdot \text{kip-in}$$

$$M_4 := \frac{M_{nuy}}{\Omega_r} = 4.2 \cdot \text{kip-in} \quad \text{RUPTURE}$$



COMMERCIAL
PRODUCTS

7008 Northland Drive
Suite 150
Minneapolis, MN 55428
(800) 337-5339 | (763) 533-2094
Fax: (763) 533-2096

Check Local Buckling - section F.3

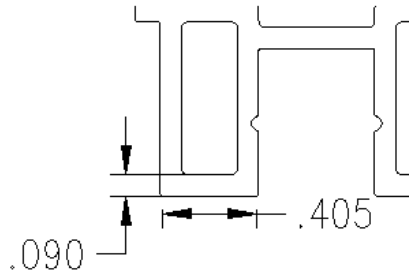

Flat Elements supported on one both edges in flexural compression (B5.5.2)

Top member in compression

$$t := 0.09\text{-in} \quad b := 0.405\text{-in} \quad \frac{b}{t} = 4.5$$

$$c_o := -c_o = -0.697\text{-in} \quad k_1 := 0.5$$

$$c_c = 0.755\text{-in} \quad k_2 := 2.04$$

$$m := \begin{cases} \left(\left(1.15 + \frac{c_o}{2c_c} \right) \right) & \text{if } -1 < \left(\frac{c_o}{c_c} \right) < 1 = 0.688 \\ \left[\frac{1.3}{\left(1 - \frac{c_o}{c_c} \right)} \right] & \text{if } \left(\frac{c_o}{c_c} \right) \leq -1 \\ 0.65 & \text{if } c_c = -c_o \end{cases}$$

$$\lambda_1 := \frac{B_{br} - 1.5 \cdot F_{cy}}{m \cdot D_{br}} = 32.793 \quad \lambda_2 := \frac{k_1 \cdot B_{br}}{m \cdot D_{br}} = 87.763$$

$$F_b := \begin{cases} 1.5 \cdot F_{cy} & \text{if } \frac{b}{t} \leq \lambda_1 \\ B_{br} - m \cdot D_{br} \cdot \left(\frac{b}{t} \right) & \text{if } \lambda_1 < \frac{b}{t} < \lambda_2 \\ \frac{k_2 \cdot \sqrt{B_{br} \cdot E}}{m \cdot \frac{b}{t}} & \text{otherwise} \end{cases} = 37.5\text{-ksi}$$

$$M_5 := \frac{F_b \cdot S_y}{\Omega} = 6.619\text{-kip-in} \quad \text{WEAK AXIS LOCAL BUCKLING}$$

Note: Lateral Torsional Buckling does NOT Control

Strong Axis Bending Capacity

$$M_{bx} := \min(M_1, M_2) = 4.506\text{-kip-in}$$

Weak Axis Bending Capacity

$$M_{by} := \min(M_3, M_4, M_5) = 4.136\text{-kip-in}$$

$M_n = 4.5\text{ k-in}$, 2% lower than applied moment from vertical 200 lb load. **OK**, minimum yield strength was used.



COMMERCIAL
PRODUCTS

7008 Northland Drive
Suite 150
Minneapolis, MN 55428
(800) 337-5339 | (763) 533-2094
Fax: (763) 533-2096

4.3.1.2 Horizontal moment capacity

Custom extrusion design per ADM 2015

Properties

6063-T6

$$F_{ty} := 25 \cdot \text{ksi}$$

$$E := 10100 \cdot \text{ksi}$$

$$k_1 := 0.35$$

$$F_u := 30 \cdot \text{ksi}$$

$$G := 3800 \cdot \text{ksi}$$

$$k_2 := 2.27$$

$$F_{cy} := 25 \cdot \text{ksi}$$

$$L_b := 96 \cdot \text{in}$$

$$F_{su} := 0.6 \cdot F_u = 18 \cdot \text{ksi}$$

$$K := 1.0$$

$$F_{sy} := 0.6 \cdot F_{ty} = 15 \cdot \text{ksi}$$

$$k_t := 1.0$$

$$C_b := 1.0 \quad \text{conservatively can be left as 1.0}$$

Section properties

$$c_c := 0.87 \cdot \text{in} \quad \text{compression side}$$

$$I_x := 0.1497 \cdot \text{in}^4$$

$$Z_x := 0.346 \cdot \text{in}^3$$

$$c_o := 0.87 \cdot \text{in}$$

$$I_y := 0.203 \cdot \text{in}^4$$

$$A_g := 0.7113 \cdot \text{in}^2$$

$$Z_y := 0.273 \cdot \text{in}^3$$

$$S_x := \frac{I_x}{c_c} = 0.172 \cdot \text{in}^3$$

$$r_x := \sqrt{\frac{I_x}{A_g}} = 0.459 \cdot \text{in}$$

$$S_y := \frac{I_y}{c_o} = 0.233 \cdot \text{in}^3$$

$$r_y := \sqrt{\frac{I_y}{A_g}} = 0.534 \cdot \text{in}$$

Resistance and safety Factors

$$\Omega := 1.65$$

$$\Omega_r := 1.95$$



COMMERCIAL
PRODUCTS

7008 Northland Drive
Suite 150
Minneapolis, MN 55428
(800) 337-5339 | (763) 533-2094
Fax: (763) 533-2096

Design of Members for Flexure Chapter F

Check yielding and rupture - section F.2

Yielding

$$Z_x \cdot F_{cy} = 8.65 \cdot \text{kip} \cdot \text{in} \quad 1.5 \cdot S_x \cdot F_{cy} = 6.453 \cdot \text{kip} \cdot \text{in} \quad k_t = 1.0 \quad \text{Dependent on type of Aluminum}$$

$$M_{\text{nu}x} := \begin{cases} Z_x \cdot F_{cy} & \text{if } Z_x \cdot F_{cy} \leq 1.5 \cdot S_x \cdot F_{cy} \\ 1.5 \cdot S_x \cdot F_{cy} & \text{if } 1.5 \cdot S_x \cdot F_{cy} < Z_x \cdot F_{cy} \end{cases} = 6.453 \cdot \text{kip} \cdot \text{in}$$

$$M_1 := \frac{M_{\text{nu}x}}{\Omega} = 3.911 \cdot \text{kip} \cdot \text{in} \quad \text{YIELDING}$$

Rupture

$$M_{\text{nu}rx} := \frac{Z_x \cdot F_u}{k_t} = 10.38 \cdot \text{kip} \cdot \text{in}$$

$$M_2 := \frac{M_{\text{nu}rx}}{\Omega_r} = 5.323 \cdot \text{kip} \cdot \text{in} \quad \text{RUPTURE}$$

Yielding

$$Z_y \cdot F_{cy} = 6.825 \cdot \text{kip} \cdot \text{in} \quad 1.5 \cdot S_y \cdot F_{cy} = 8.75 \cdot \text{kip} \cdot \text{in} \quad k_t = 1.0 \quad \text{Dependent on type of Aluminum}$$

$$M_{\text{nu}y} := \begin{cases} Z_y \cdot F_{cy} & \text{if } Z_y \cdot F_{cy} \leq 1.5 \cdot S_y \cdot F_{cy} \\ 1.5 \cdot S_y \cdot F_{cy} & \text{if } 1.5 \cdot S_y \cdot F_{cy} < Z_y \cdot F_{cy} \end{cases} = 6.825 \cdot \text{kip} \cdot \text{in}$$

$$M_3 := \frac{M_{\text{nu}y}}{\Omega} = 4.136 \cdot \text{kip} \cdot \text{in} \quad \text{YIELDING}$$

Rupture

$$M_{\text{nu}ry} := \frac{Z_y \cdot F_u}{k_t} = 8.19 \cdot \text{kip} \cdot \text{in}$$

$$M_4 := \frac{M_{\text{nu}ry}}{\Omega_r} = 4.2 \cdot \text{kip} \cdot \text{in} \quad \text{RUPTURE}$$

Note: Lateral Torsional and Local Buckling do NOT Control

Strong Axis Bending Capacity

$$M_{\text{bx}} := \min(M_1, M_2) = 3.911 \cdot \text{kip} \cdot \text{in}$$

Weak Axis Bending Capacity

$$M_{\text{by}} := \min(M_3, M_4) = 4.136 \cdot \text{kip} \cdot \text{in}$$

$$M_n = 4.1 \text{ k} - \text{in} \quad (\text{controls for wind load})$$



COMMERCIAL
PRODUCTS

7008 Northland Drive
Suite 150
Minneapolis, MN 55428
(800) 337-5339 | (763) 533-2094
Fax: (763) 533-2096

4.3.2 Bottom rail

This rail is subject to a horizontal live load of 50 lbs applied at the center of an 8ft span over 1 square foot.

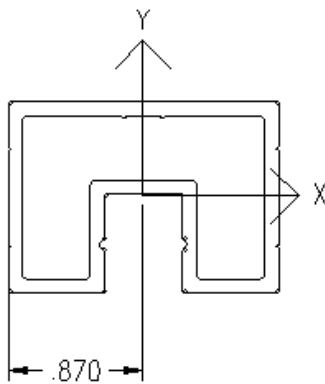

----- REGIONS -----			
Area:	0.6139		
Perimeter:	13.7053		
Bounding box:	X: -0.8700	--	0.8700
Y:	-0.6247	--	0.6053
Centroid:	X: 0.0000		
Y:	0.0000		
Moments of inertia:	X: 0.1137		
Y:	0.2173		
Product of inertia:	XY: 0.0000		
Radii of gyration:	X: 0.4303		
Y:	0.5950		
Principal moments and X-Y directions about centroid:			
I:	0.1137	along	[1.0000 0.0000]
J:	0.2173	along	[0.0000 1.0000]
K:	Zy = 0.325		IN ³



COMMERCIAL
PRODUCTS

7008 Northland Drive
Suite 150
Minneapolis, MN 55428
(800) 337-5339 | (763) 533-2094
Fax: (763) 533-2096

4.3.2.1 Horizontal moment capacity

Custom extrusion design per ADM 2015

Properties

6063-T6

$$F_{ty} := 25 \cdot \text{ksi}$$

$$E := 10100 \cdot \text{ksi} \quad k_1 := 0.35$$

$$F_u := 30 \cdot \text{ksi}$$

$$G := 3800 \cdot \text{ksi} \quad k_2 := 2.27$$

$$F_{cy} := 25 \cdot \text{ksi}$$

$$L_b := 96 \cdot \text{in}$$

$$F_{su} := 0.6 \cdot F_u = 18 \cdot \text{ksi}$$

$$K := 1.0$$

$$F_{sy} := 0.6 \cdot F_{ty} = 15 \cdot \text{ksi}$$

$$k_t := 1.0$$

$$C_b := 1.0 \quad \text{conservatively can be left as 1.0}$$

Section properties

$$c_o := 0.87 \cdot \text{in} \quad \text{compression side}$$

$$I_y := 0.2173 \cdot \text{in}^4 \quad A_g := 0.6139 \cdot \text{in}^2 \quad Z_y := 0.325 \cdot \text{in}^3$$

$$S_y := \frac{I_y}{c_o} = 0.25 \cdot \text{in}^3 \quad r_y := \sqrt{\frac{I_y}{A_g}} = 0.595 \cdot \text{in}$$

Resistance and safety Factors

$$\Omega := 1.65 \quad \Omega_r := 1.95$$



COMMERCIAL
PRODUCTS

7008 Northland Drive
Suite 150
Minneapolis, MN 55428
(800) 337-5339 | (763) 533-2094
Fax: (763) 533-2096

Design of Members for Flexure Chapter F

Check yielding and rupture - section F.2

Yielding

$$Z_y \cdot F_{cy} = 8.125 \cdot \text{kip} \cdot \text{in} \quad 1.5 \cdot S_y \cdot F_{cy} = 9.366 \cdot \text{kip} \cdot \text{in} \quad k_t := 1.0 \quad \text{Dependent on type of Aluminum}$$

$$M_{nuy} := \begin{cases} Z_y \cdot F_{cy} & \text{if } Z_y \cdot F_{cy} \leq 1.5 \cdot S_y \cdot F_{cy} \\ 1.5 \cdot S_y \cdot F_{cy} & \text{if } 1.5 \cdot S_y \cdot F_{cy} < Z_y \cdot F_{cy} \end{cases} = 8.125 \cdot \text{kip} \cdot \text{in}$$

$$M_1 := \frac{M_{nuy}}{\Omega} = 4.924 \cdot \text{kip} \cdot \text{in} \quad \text{YIELDING}$$

Rupture

$$M_{nury} := \frac{Z_y \cdot F_u}{k_t} = 9.75 \cdot \text{kip} \cdot \text{in}$$

$$M_2 := \frac{M_{nury}}{\Omega_r} = 5 \cdot \text{kip} \cdot \text{in} \quad \text{RUPTURE}$$

Note: Lateral Torsional and Local Buckling do NOT Control

Weak Axis Bending Capacity

$$M_{by} := \min(M_1, M_2) = 4.924 \cdot \text{kip} \cdot \text{in}$$

$$M_n = 4.9 \text{ k} - \text{in}$$



COMMERCIAL
PRODUCTS

7008 Northland Drive
Suite 150
Minneapolis, MN 55428
(800) 337-5339 | (763) 533-2094
Fax: (763) 533-2096

4.3.3  L-bracket

Attaching L-Brackets to Top and Bottom Rails

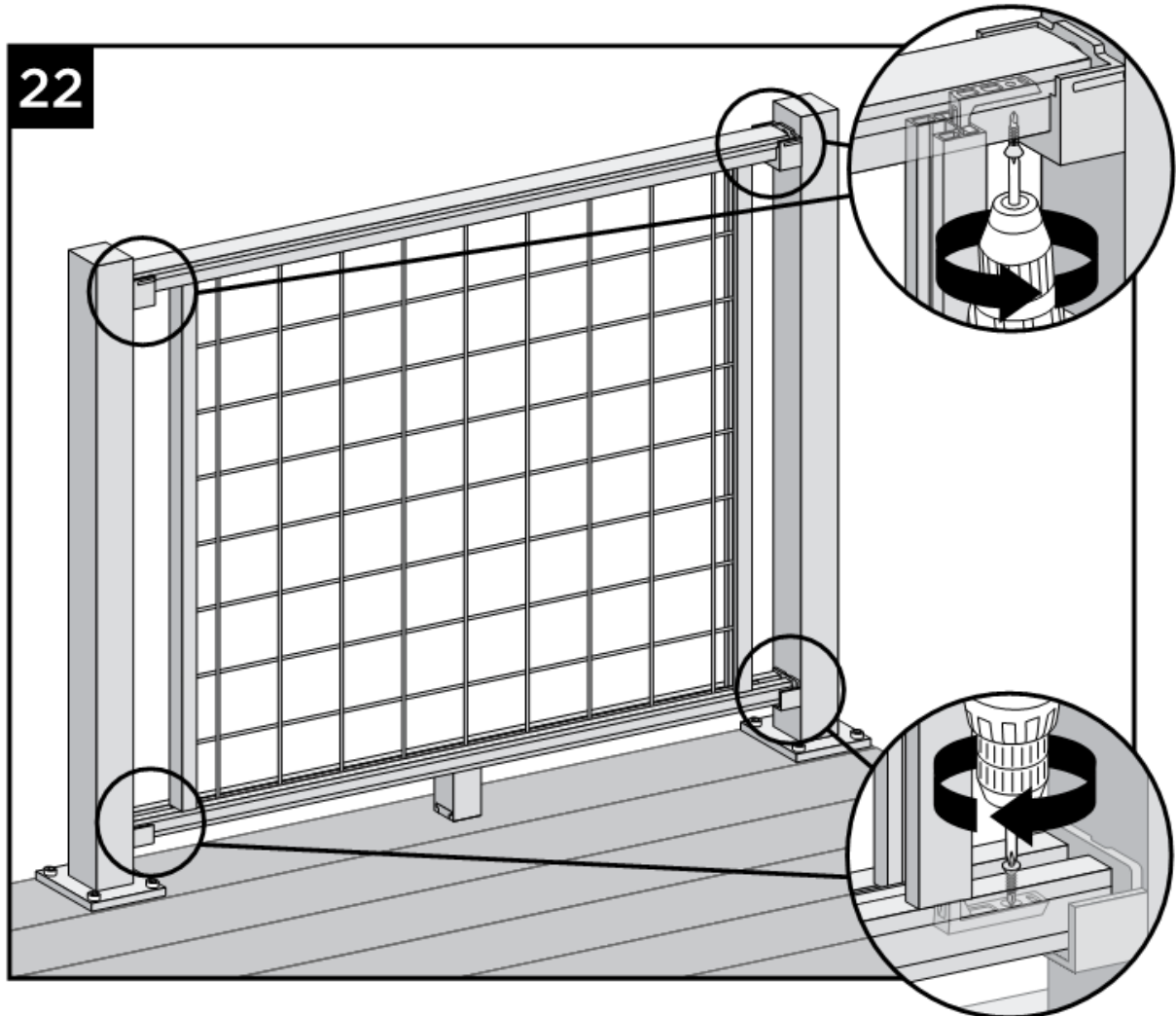

This connection and bracket are adequate by inspection since the load applied is a fraction of the 50 lbs over 1 sq ft infill load.



COMMERCIAL
PRODUCTS

7008 Northland Drive
Suite 150
Minneapolis, MN 55428
(800) 337-5339 | (763) 533-2094
Fax: (763) 533-2096

4.3.4 Test results

Similar brackets were tested. The connection of the brackets to the post are the same while the castings have little variance geometrically.

Results are reported from Architectural Testing report number C7526.01-119-19 revision 1 dated 2/20/14 and Intertek report E3233.01-119-19 revision 1 dated 3/24/15. The former test report was for the Trex Reveal system, which utilizes the same post, top rail and bottom rail including attachment brackets as does the rod rail system. The tests for the posts are not applicable since the alloy used in testing is a higher strength alloy than is used in production. The alloy used for the top rail in testing (6005-T5) is also different than that used in production but is the same strength. The latter Intertek test was used with the composite sleeves and spacer blocks, and thus indicates that they are also code compliant.



Photo No. 2



COMMERCIAL
PRODUCTS

7008 Northland Drive
Suite 150
Minneapolis, MN 55428
(800) 337-5339 | (763) 533-2094
Fax: (763) 533-2096

4.3.4.1 Attachment brackets

Test No. 5 - Test Date: 05/06/13			
Design Load: 200 lb Concentrated Load at Both Ends of Top Rail (Brackets)			
Load Level ¹	Test Load (lb)	E.T. (min:sec)	Result
1000 lb (2.50 x D.L.) x 2	1000 - 1011	01:05 – 02:07	Each end withstood load equal to or greater than 500 lb for one full minute without failure

¹ Load was imposed on both ends of rail using a spreader beam; therefore, loads were doubled.

The brackets averaged ~1000 lbs for all samples → brackets are adequate.



COMMERCIAL
PRODUCTS

7008 Northland Drive
Suite 150
Minneapolis, MN 55428
(800) 337-5339 | (763) 533-2094
Fax: (763) 533-2096

5 Conclusion

Component	Conclusion
Top rail	Adequate
Rail Caps	Adequate
Bottom rail	Adequate
Rail mounting brackets	Adequate
Posts	Adequate*
Baseplates and base welds	Adequate
Mesh	Adequate
Anchorage	Adequate

*Controlling component

**→ Railing meet the requirements of IRC 2015 with up to 6' post spacing.
The capacity is limited by the strength of the post.**



COMMERCIAL
PRODUCTS

7008 Northland Drive
Suite 150
Minneapolis, MN 55428
(800) 337-5339 | (763) 533-2094
Fax: (763) 533-2096

6 Appendix A – aluminum tensile test results

6.1 Description

Tests were completed by Element Materials Technology in St. Paul, MN. Tests were conducted in accordance with ASTM B557-14 and ASTM E8-E8M-13a. 1/8" T4 and T6 material was tested. The following conditions were tested:

Description	Tag	Number
T4 samples	T4	3
Heat treat T4 to T6	T4H	10
Welded T4	T4W	10
Welded T4 heat treat to T6	T4WH	10
T6 samples	T6	3
Heat treat T6	T6H	10
Welded T6	T6W	10
Welded T6 heat treat to T6	T6WH	10
Weld deposit on T6 base metal	T6WB	5
Weld deposit on T6 base metal, HT	T6WBH	5
Weld deposit on T4 base metal	T4WB	5
Weld deposit on T4 base metal, HT	T4WBH	5

Notes:

- *Filler metal 5356 used on all welded samples
- *TIG process used with CJP butt weld for all 'W' and 'WH' samples
- *TIG process used with 1/8" fillet on both sides of sample for all 'WB' and 'WBH' samples
- *Samples with tag 'H' heat treated at 350°F for 8 hours and 8 minutes (see certification)
- *All samples were created from cold processes (shear/punch)



COMMERCIAL
PRODUCTS

7008 Northland Drive
Suite 150
Minneapolis, MN 55428
(800) 337-5339 | (763) 533-2094
Fax: (763) 533-2096

Flame Metals Processing Corp.
Certification

Order No.: 531050
Date: 10/03/2014
Entry Date: 10/02/2014
Page: 1 of 1

To:

STAGING CONCEPTS ACQUISITION,
7008 NORTHLAND DR
SUITE 150
BROOKLYN PARK MN 55428

Purchase Order No.: 65771
Packing List No.:
Material: 6061

We are pleased to provide you with the following Certification

Quantity	Part Number / Part Name / Part Description	Pounds
10	T4H 6061-T4 Precipitation harden to condition T6	
10	T4WH 6061-T4 Precipitation harden to condition T6	
10	T6H 6061-T6 Run to process for Precipitation hardening T4 to condition T6	
10	T6WH 6061-T6 Run to process for Precipitation hardening T4 to condition T6	3.04

Insp. Type	Scale	Minimum	Maximum	Number	Other	Inspection ID#
Customer Requirements:						
Hardnss	HRB	42.				

Results:

Parts were processed according to the procedure and industry standards.

Processed ok.
Final hardness HRB:
T4 WH: 44.2
T4 H: 46.5
T6 H: 45.6
T6 WH: 46.5

Parts were tempered at 350°F for 8 hours and 8 minutes.
Processing chart attached.
Ok to ship.

Madison Aguirre
10/3/2014

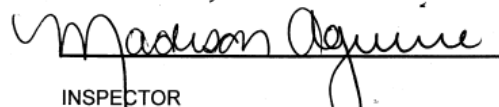
INSPECTOR
Flame Metals Processing Corporation



COMMERCIAL
PRODUCTS

7008 Northland Drive
Suite 150
Minneapolis, MN 55428
(800) 337-5339 | (763) 533-2094
Fax: (763) 533-2096

6.2 Results

Derivation of yield (0.2% offset) and ultimate strength based on the samples values were calculated based on EN 1990-2002, Appendix D, Table D1. This method

D7.2 Assessment via the characteristic value

(1) The design value of a property X should be found by using :

$$X_d = \eta_d \frac{X_{k(n)}}{\gamma_m} = \frac{\eta_d}{\gamma_m} m_X \{1 - k_n V_X\} \quad (D.1)$$

Table D1 : Values of k_n for the 5% characteristic value

n	1	2	3	4	5	6	8	10	20	30	∞
V_X known	2,31	2,01	1,89	1,83	1,80	1,77	1,74	1,72	1,68	1,67	1,64
V_X unknown	-	-	3,37	2,63	2,33	2,18	2,00	1,92	1,76	1,73	1,64

Where,

m_x = mean (average) value

k_n = characteristic fractile value given in Table D1 and based on the number of test samples

V_x = coefficient of variation

η_d = conversion factor, if required (=1 in this case)

γ_m = partial resistance (safety factor); factor depends on application. In this case, safety factors will be included in design per ADM requirements, thus factor in this statistical analysis = 1

The coefficient of variation was calculated as 0.02 and was based on mill certification data from various runs of aluminum as received. See Figure 1.



COMMERCIAL
PRODUCTS

7008 Northland Drive
Suite 150
Minneapolis, MN 55428
(800) 337-5339 | (763) 533-2094
Fax: (763) 533-2096

6061-T6 mill certification data							
yield	average	std. dev.	COV	ultimate	average	std. dev.	COV
43.5	42.86	0.92	0.02	49	48.19	0.85	0.02
44.2							
43.4							
43.8							
43							
43.1							
42.2							
42.4							
42.4							
42.3							
42.3							
42.3							
43.6							
43.7							
43.5							
43.4							
43.5							
40.9							
40.9							

Figure 1 - Vx (COV) calculation



COMMERCIAL
PRODUCTS

7008 Northland Drive
Suite 150
Minneapolis, MN 55428
(800) 337-5339 | (763) 533-2094
Fax: (763) 533-2096

The values for yield strength and ultimate strength are calculated per equation D.1 shown previously.

All values in ksi

Material/tag	Sample no.	Yield	Average	Std. Dev.	kn 5%	Yield strength	Ultimate	Average	Std. Dev.	kn 5%	Ultimate strength
T4	1	29.7	29.80	0.10	1.89	28.6	42.5	42.53	0.25	1.89	41.1
	2	29.9					42.8				
	3	29.8					42.3				
T4H	1	43.1	42.98	0.25	1.72	41.4	46.3	46.47	0.28	1.72	45.1
	2	43					46.8				
	3	43.1					46.7				
	4	43.1					46.6				
	5	43.5					46.7				
	6	43					46.8				
	7	42.8					46.1				
	8	42.7					46.2				
	9	42.9					46.3				
	10	42.6					46.2				
T4W	1	22.5	22.98	2.39	1.72	22.1	31.6	30.66	0.72	1.74	29.7
	2	19.1					NA - weld fail				
	3	21.5					30.3				
	4	28.1					31				
	5	24.7					30.8				
	6	22.6					30.1				
	7	21.3					NA - weld fail				
	8	22.4					30.7				
	9	23.5					31.4				
	10	24.1					29.4				
T4WH	1	26.1	26.61	0.92	1.72	25.6	33.5	33.98	0.44	1.73	32.9
	2	26.5					33.7				
	3	26.2					34.2				
	4	28.9					34.7				
	5	26.2					34				
	6	26.6					34.5				
	7	26					33.6				
	8	27.2					34.1				
	9	26.8					33.5				
	10	25.6					NA - weld fail				
T4WB	1	26.7	27.40	0.58	1.8	26.3	33.2	33.50	0.41	1.8	32.2
	2	27.9					33.5				
	3	27.5					33.3				
	4	28					33.3				
	5	26.9					34.2				
T4WBH	1	33.4	31.66	2.96	1.8	30.4	38.8	38.84	0.45	1.8	37.3
	2	26.6					38.2				
	3	32					39.1				
	4	34.1					39.4				
	5	32.2					38.7				



COMMERCIAL
PRODUCTS

7008 Northland Drive
Suite 150
Minneapolis, MN 55428
(800) 337-5339 | (763) 533-2094
Fax: (763) 533-2096

T6	1	40.8	41.10	0.30	1.89	39.4	47.8	47.97	0.15	1.89	46.4
	2	41.4					48.1				
	3	41.1					48				
T6H	1	41.8	42.28	0.28	1.72	40.7	46.5	46.66	0.18	1.72	45.3
	2	42.7					47.1				
	3	42.4					46.7				
	4	42.4					46.7				
	5	42.3					46.6				
	6	42.3					46.7				
	7	42.3					46.6				
	8	42.6					46.7				
	9	42.1					46.5				
	10	41.9					46.5				
T6W	1	21.4	22.48	1.06	1.72	21.6	29.6	30.02	0.83	1.72	29.1
	2	22.2					31.4				
	3	22.2					30.3				
	4	23					29				
	5	25					30				
	6	22.6					30.6				
	7	22.5					29.4				
	8	21.3					29.4				
	9	21.7					29.3				
	10	22.9					31.2				
T6WH	1	27.7	27.86	1.27	1.72	26.8	NA - weld fail	34.29	0.35	1.76	33.2
	2	27.2					33.6				
	3	28.7					NA - weld fail				
	4	27.7					34.2				
	5	27.3					34.6				
	6	27					34.1				
	7	30.3					34.5				
	8	29.4					34.5				
	9	27.4					34.5				
	10	25.9					NA - weld fail				
T6WB	1	25.1	24.40	0.91	1.8	23.5	31	30.62	0.60	1.8	29.4
	2	24.6					30.6				
	3	22.9					29.6				
	4	24.3					30.8				
	5	25.1					31.1				
T4WBH	1	29.5	29.46	0.32	1.8	28.3	36.1	36.20	0.35	1.8	34.8
	2	29.3					35.9				
	3	29					36.2				
	4	29.8					36.8				
	5	29.7					36				



COMMERCIAL
PRODUCTS

7008 Northland Drive
Suite 150
Minneapolis, MN 55428
(800) 337-5339 | (763) 533-2094
Fax: (763) 533-2096

6.3 Derived properties

The following figure summarizes the values calculated in section 8.2.

All values in ksi

Properties		
T4	yield	28.6
	ultimate	41.1
T4 - welded	yield	22.1
	ultimate	29.7
T4 heat treated	yield	41.4
	ultimate	45.1
T4 heat treated/welded	yield	25.6
	ultimate	32.9
T4 heat affected	yield	26.3
	ultimate	32.2
T4 heat affected/HT	yield	30.4
	ultimate	37.3
T6	yield	39.4
	ultimate	46.4
T6 - welded	yield	21.6
	ultimate	29.1
T6 heat treated	yield	40.7
	ultimate	45.3
T6 heat treated/welded	yield	26.8
	ultimate	33.2
T6 heat affected	yield	23.5
	ultimate	29.4
T6 heat affected/HT	yield	28.3
	ultimate	34.8



COMMERCIAL
PRODUCTS

7008 Northland Drive
Suite 150
Minneapolis, MN 55428
(800) 337-5339 | (763) 533-2094
Fax: (763) 533-2096

6.4 Conclusions and applicability of data

The following conclusions can be made from the data:

- 1) Heat treating T4 material (unwelded) brings it to T6 strength
- 2) T4 and T6 welded material has essentially the same strength properties
- 3) T4 welded material is reduced to ~78% of its as received yield, T6 welded material is reduced to ~56% of its as received yield
- 4) Heat treating welded material recovers 15-24% of the strength
- 5) Heat affected and heat treated material (i.e., fillet weld is not through material) has ~30% more strength than welded material
- 6) Heat treatment does not have a negative effect on base material outside of the heat-affected zone or on filler material

The data indicates that for welded areas on T4 and T6 material that are heat treated, the minimum yield used for design purposes is 25.6 ksi. Conservatively, this value is used rather than 30.4 ksi for heat affected and heat treated areas. This is an added measure of safety to account for the fillet weld (or heat affected zone) penetrating through the material, which may be the case for larger fillet welds.