



DuPont™ Self-Adhered Flashing Systems Products

Installation of Integral Flanged Windows in Recessed Openings Before Water-Resistive Barrier (WRB) Is Installed

For Greater Than 4" Recess Using Single and Double Stud Window Framing

INSTALLATION GUIDELINE

FOR BUILDINGS LESS THAN 5 STORIES AND LOW-RISE MULTI-FAMILY RESIDENTIAL BUILDINGS LESS THAN 6 STORIES



Tyvek®

Installation of Integral Flanged Windows in Recessed Openings Greater than 4" Before Water-Resistive Barrier (WRB) Is Installed

DuPont™ Self-Adhered Flashing Systems Products – Installation Guidelines for Greater Than 4" Recess Using Single and Double Stud Window Framing

This installation bulletin includes the steps required to fabricate and install a self-adhered flashing solution for the inside corners of recessed integral flanged windows using DuPont™ FlexWrap™ NF and provides instructions for flashing windows when they are installed before the DuPont™ Tyvek® WRB.

Table of Contents

Applicable Products	2
Required Materials Based on Project Requirements, Details, and Specifications.....	3
Warranty	3
General Instructions	3
Key Installation Requirements for Drainable Window / Door Installation Under the Limited Product and Labor Warranty.....	4
Field Preparation of Recessed Window Corner Using DuPont™ FlexWrap™ NF	5
Installation Method 1: Depth of the Recess is Less Than 1/2 the Width of the Recess.....	8
Installation Method 2: Depth of the Recess is Greater Than 1/2 the Width of the Recess.....	19
Corner Release Paper Removal Guide for ALTERNATIVE METHOD described on page 7	31

Applicable Products

DuPont™ Self-Adhered Flashing Systems Products

PRODUCT	WIDTH
DuPont™ FlexWrap™ NF	6 in 9 in
DuPont™ StraightFlash™	4 in 9 in
DuPont™ Flashing Tape	4 in 6 in 9 in 12 in

Water-Resistive Barriers (WRB)

PRODUCT	DIMENSIONS	AREA
DuPont™ Tyvek® HomeWrap®	3 ft x 100 ft	300 sq ft
	3 ft x 165 ft	495 sq ft
	5 ft x 200 ft	1,000 sq ft
	9 ft x 100 ft	900 sq ft
	9 ft x 150 ft	1,350 sq ft
	10 ft x 100 ft 10 ft x 150 ft	1,000 sq ft 1,500 sq ft
DuPont™ Tyvek® StuccoWrap®	5 ft x 200 ft	1,000 sq ft
DuPont™ Tyvek® DrainWrap™	9 ft x 125 ft	1,125 sq ft
	10 ft x 125 ft	1,250 sq ft
DuPont™ Tyvek® ThermaWrap™ LE	5 ft x 150 ft	750 sq ft
	9 ft x 100 ft	900 sq ft
DuPont™ Tyvek® CommercialWrap®	5 ft x 200 ft	1,000 sq ft
	10 ft x 125 ft	1,250 sq ft
DuPont™ Tyvek® CommercialWrap® D	5 ft x 200 ft	1,000 sq ft
	10 ft x 125 ft	1,250 sq ft

Installation of Integral Flanged Windows in Recessed Openings Greater than 4" Before Water-Resistive Barrier (WRB) Is Installed

Required Materials Based on Project Requirements, Details, and Specifications

PRODUCT

DuPont™ Tyvek® Tape

DuPont™ Tyvek® Wrap Cap Fasteners or recommended fastening system

DuPont™ Window & Door Foam

DuPont™ Residential Sealant, or other recommended sealant*

DuPont™ Adhesive/Primer

Backer Rod

Brushes for Surface Preparation

J-Roller

Apply per manufacturers' guidelines. For non DuPont products, DuPont assumes no liability in use of recommended products; installers need to evaluate suitability of recommended products in their end-use applications.

Warranty

Please refer to the [DuPont Weatherization Products 10-Year Limited Warranty for Buildings Less Than 5 Stories and Low-Rise Multi-Family Residential Buildings Less Than 6 Stories](#).

NOTE: In order to make a claim under the DuPont Weatherization Products 10-Year Limited Product and Labor Warranty, you must have met all of the terms and conditions of the warranty, including use of the applicable DuPont Installation Guidelines. In the event that a specific detail or installation technique is not covered in the DuPont Installation Guidelines at the time you are building, then the Key Installation Requirements outlined in this document must have been followed in order to make a claim under the warranty. It is in the sole discretion of DuPont to determine if full compliance with the Key Installation Requirements exists. Please contact DuPont or a DuPont™ Tyvek® Specialist if you have any questions regarding any DuPont Installation Guideline.

General Instructions

These installation guidelines are intended **for buildings less than 5 stories and low-rise multi-family residential buildings less than 6 stories** when performance requirements do not exceed ASTM E1677 (65 mph equivalent structural load and 15 mph equivalent wind-driven rain water infiltration), and window/door design ratings that do not exceed DP45.

DuPont™ self-adhered flashing systems products should be installed on clean, dry surfaces that are free of frost. Wipe surfaces to remove moisture, dirt, grease and other debris that could interfere with adhesion.

Apply pressure along entire surface of flashing for a good bond using firm hand pressure, J-roller, or alternate tool without sharp edges (such as a plastic carpet tuck tool) to assist with application of uniform pressure during installation of DuPont™ self-adhered flashing systems products.

Remove all wrinkles and bubbles that may allow for water intrusion by smoothing surface and repositioning as necessary.

When flashing the sill area for windows and doors, DuPont recommends the use of 6" wide DuPont™ FlexWrap™ NF for 2" x 4" framing and 9" wide DuPont™ FlexWrap™ NF for 2" x 6" framing. As an option, if a rigid back dam is desired, cut the corner back dam the length of the sill and nail into place on the interior edge of the sill prior to installation of DuPont™ FlexWrap™ NF. Then install DuPont™ FlexWrap™ NF over sill and corner guard back dam. If using 6" DuPont™ FlexWrap™ NF with optional rigid back dam, seal ends of corner guard with DuPont™ Residential Sealant or recommended sealant.

Door and window rough sill framing must be level or slightly sloped to the exterior to ensure proper drainage to the exterior. This best practice ensures continuous support with positive slope to the exterior.

DuPont™ self-adhered flashing systems products are not intended for through-wall flashing applications.

DuPont™ Residential Sealant should be tooled flat to allow the natural curing process to create a concave joint.

Please contact your local DuPont™ Tyvek® Specialist for additional information and installation support.

Installation of Integral Flanged Windows in Recessed Openings Greater than 4" Before Water-Resistive Barrier (WRB) Is Installed

DO NOT STRETCH DuPont™ FlexWrap™ NF when installing along the length of sills or jambs. DuPont™ FlexWrap™ NF is only intended to be extended when covering corners or curved sections.

DuPont™ self-adhered flashing systems products perform best when installed at temperatures above 25°F (-4°C).

Avoid placing DuPont™ Tyvek® Wrap Cap Fasteners where flashing or DuPont™ Tyvek® Tape will be installed; however, DuPont™ Tyvek® Wrap Cap Fasteners can be applied over the flashing.

Adverse weather conditions or cold temperatures may require use of a primer to promote adhesion of DuPont™ self-adhered flashing products to most common building materials. Concrete, masonry, and fiber-faced exterior gypsum board require the use of DuPont™ Adhesive/Primer.

Please call 1-800-44-Tyvek (800-448-9835), visit www.weatherization.tyvek.com, or consult your local DuPont™ Tyvek® Specialist for additional information and installation support.

Key Installation Requirements for Drainable Window / Door Installation Under the Limited Product and Labor Warranty

When flashing windows or doors, the following principles must be followed:

- When installed properly, DuPont™ StraightFlash™, DuPont™ FlexWrap™ NF, and DuPont™ Flashing Tape provide nail sealability at window/door openings to help protect critical window-wall interfaces. Metal sill pan flashing may be used, but must not replace flexible sill flashing that provides nail sealability.
- DuPont™ self-adhered flashing systems products comply with AAMA 711-13, *Voluntary Specification for Self Adhering Flashing Used for Installation of Exterior Wall Fenestration Products*, which has a modified version of ASTM D 1970 that is more representative for vertical wall applications.
- Direct water onto an acceptable air and water barrier drainage plane with an unobstructed path to the exterior of the wall. Provide a drainage path for any water intrusion through the window/door attachment system that collects at the sill.
- Properly integrate flashing with acceptable DuPont™ Tyvek® WRB in accordance with the details in this installation guideline. DuPont™ self-adhered flashing systems products must be applied with a minimum 2" lap onto the WRB.
- DuPont requires that DuPont™ FlexWrap™ NF and StraightFlash™ be covered within nine months (270 days) of installation. DuPont requires that DuPont™ Flashing Tape be covered within four months (120 days) of installation.
- Ensure that window / door and flashing system design takes into account common factors that will impact performance, such as:
 - Climate considerations: Rainfall, Wind, Temperature (hot / cold cycles), Humidity
 - Building design: Window / Wall Design (overhangs, recessed openings, bump-outs), Wall Assembly (wood frame or masonry), Window System (wood or vinyl), New Construction or Replacement Window drainage path
 - UV exposure prior to the construction of the exterior facade
- Field testing the window / door and wall installation as a complete system is a recommended best practice.
- Use of trained installers is highly recommended.

Installation of Integral Flanged Windows in Recessed Openings Greater than 4" Before Water-Resistive Barrier (WRB) Is Installed

Field Preparation of Recessed Window Corner Using DuPont™ FlexWrap™ NF

The method illustrated in this bulletin uses 6" wide DuPont™ FlexWrap™ NF to fabricate Recessed Window Corners for recesses that are greater than 4" deep with double stud framing. The same method can be used to create Recessed Window Corners from 9" wide DuPont™ FlexWrap™ NF. This installation guideline also applies to single stud framing which is limited to the use of 6" FlexWrap™ NF for fabrication of Recessed Window Corners. See summary of FlexWrap™ NF dimensions below and pictures to right for additional guidance.

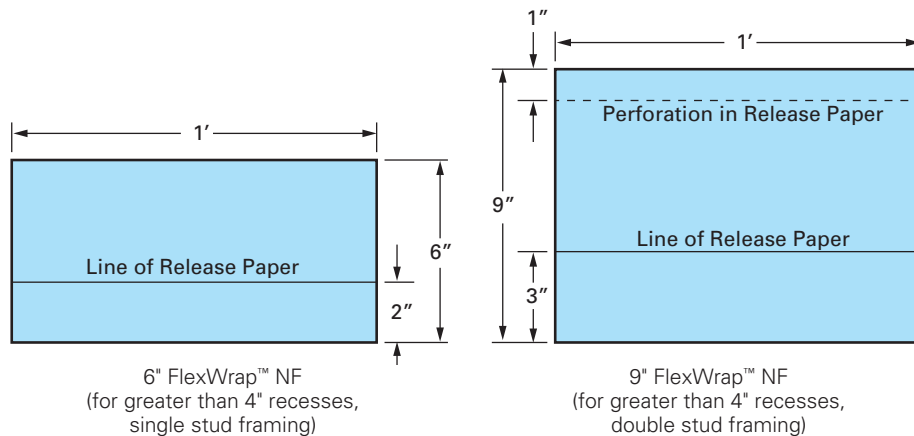

The following image shows the fabricated Recessed Window Corners for a recess that is greater than 4" deep with double stud window framing using 9" DuPont™ FlexWrap™ NF.

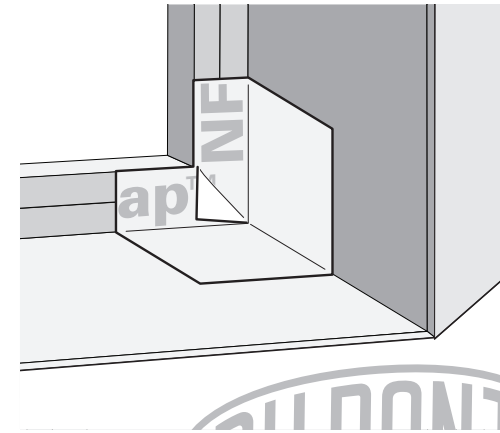

The images below show the 6" FlexWrap™ NF Recessed Window Corner installed on a single stud window. Note that the FlexWrap™ NF Recessed Window Corner extending slightly beyond the face of the stud (left) can be fully adhered into framing (right). See Step 3 for additional information.

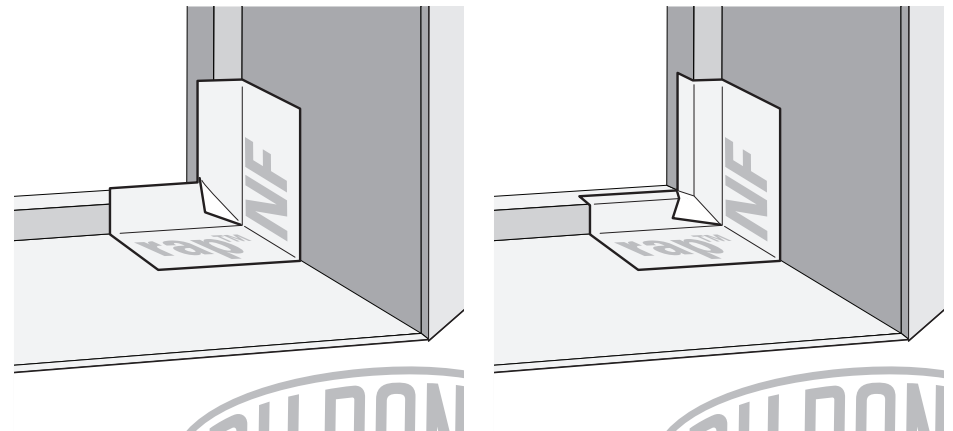

Installation of Integral Flanged Windows in Recessed Openings Greater than 4" Before Water-Resistive Barrier (WRB) Is Installed

FABRICATE FOUR RECESSED WINDOW CORNERS

A-1. Cut Four 12" Pieces of 6" DuPont™ FlexWrap™ NF



A-2. Create Horizontal CREASE A. Fold FlexWrap™ NF at release paper to break perforations and create crease.

NOTE: The narrow release paper will be used to guide corner fold in Step A-5.



A-3. Create Vertical CREASE B. Fold FlexWrap™ NF in half, lengthwise, and create sharp crease at the fold.



A-4. Set Corner Fold Width. Place index finger on the top side of the FlexWrap™ NF at the intersection of CREASE A and CREASE B.

NOTE: This will put pressure on the opposite side of release paper at the crease, and set the corner fold width.

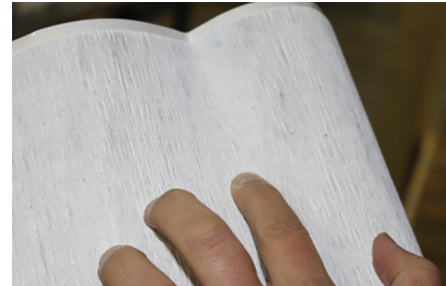

A-5. Create Corner Fold. On the reverse side of the FlexWrap™ NF, starting at the intersection of CREASE A and CREASE B, fold along CREASE B going out towards edge of narrow release paper.



Installation of Integral Flanged Windows in Recessed Openings Greater than 4" Before Water-Resistive Barrier (WRB) Is Installed

A-6. Crease Center Fold. Press firmly to create sharp crease in center and edges of fold. Sharp creases are necessary so the folds remain in the top sheet of the FlexWrap™ NF after release paper is removed.

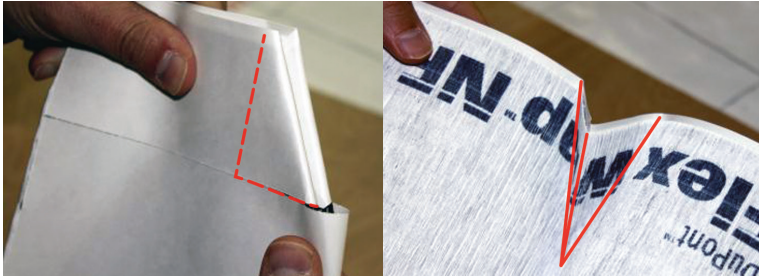

NOTE: Center crease should be sharp enough to assist in creating a ~90° fold between the two release papers at a right angle with vertical crease (Crease B), as shown below:

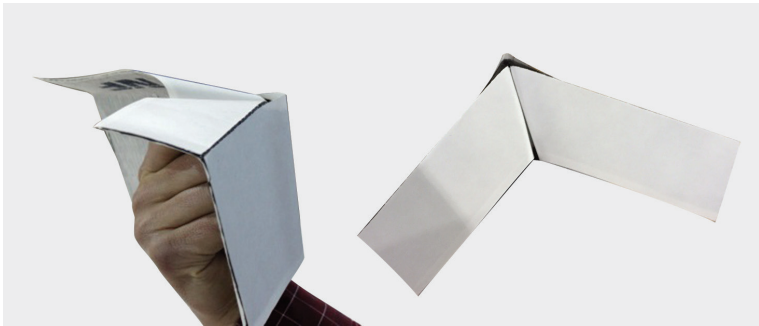

A-7. Form Recessed Window Corner. Remove narrow-width release paper and, using the creases made in Step A-6, carefully press together the exposed butyl within the corner fold to create Recessed Window Corner. Repeat with the 3 remaining 12" pieces of FlexWrap™ NF.



ALTERNATIVE METHOD: Use the guide on page 31 of this document to create a reusable template using a piece of hard/rigid plastic. Once created, the template can be used to aid in removal of the release paper from the corner section only as indicated below. The template will be placed over the 12" piece of DuPont™ FlexWrap™ NF (release paper facing up) and aligned according to the applicable marks on the template. The release paper can then be torn along the edge of the template to expose the butyl. Alternatively, the template can be used to mark the release paper for removal. In this case a straight edge can be used to assist in tearing the release paper. **Do not cut the release paper with a knife or other sharp object** as this could result in damage to the butyl and compromise protection provided by the DuPont™ FlexWrap™ NF Recessed Window Corners.

Once the release paper is removed to create a triangular area of expose butyl, fold the DuPont™ FlexWrap™ NF according to Step A-6 above to create the 90° corner and press exposed butyl together. Once the remaining narrow release paper is removed, the Recessed Window Corner is ready to install.

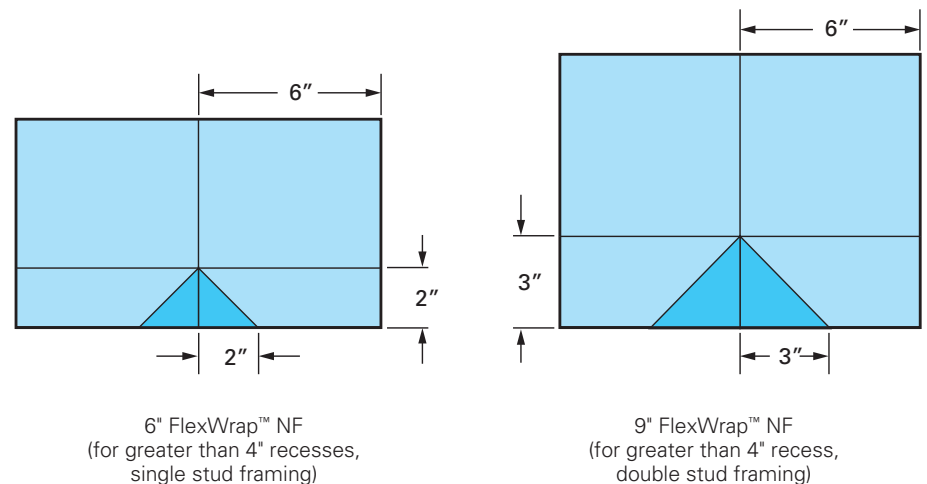

Installation of Integral Flanged Windows in Recessed Openings Greater than 4" Before Water-Resistive Barrier (WRB) Is Installed – Method 1

Installation Method 1: Depth of the Recess is Less Than 1/2 the Width of the Recess

Method 1: Used when the depth of recess is less than 1/2 the width of the recess allowing for DuPont™ Tyvek® WRB jamb flaps to be folded into the rough opening to cover jamb walls of the recess. Follow **Method 2** (page 19) when the depth of recess is greater than 1/2 the width of the recess which requires strips of DuPont™ Tyvek® WRB to cover jamb walls of the recess.

Step 1 – Install DuPont™ Tyvek® WRB Frame Around Window Rough Opening

Installation of DuPont™ Tyvek® WRB frame prior to window installation is necessary for proper shingling and integration with the DuPont™ Tyvek® WRB which will be installed after the window (see Step 16).

- A. Cut a piece of DuPont™ Tyvek® WRB that is 24" wider and 24" taller than the window rough opening to allow a 12" width around all sides.
- B. Center the piece of DuPont™ Tyvek® WRB over the rough opening and fasten along the sides and across the top using DuPont™ Tyvek® Wrap Caps or recommended fastening system. Fasteners should not be installed within 10" of the edge of the rough opening, and no fasteners should be installed within 8" of the bottom edge of the DuPont™ Tyvek® WRB.

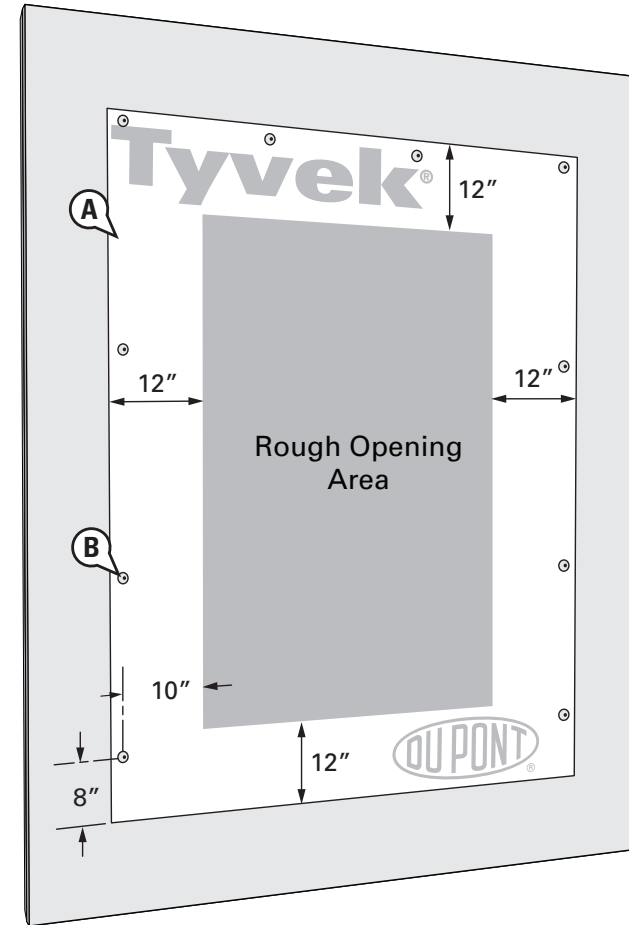

Installation of Integral Flanged Windows in Recessed Openings Greater than 4" Before Water-Resistive Barrier (WRB) Is Installed – Method 1

Step 2 – Prepare DuPont™ Tyvek® WRB Frame for Window Installation

- Make an "I-Cut" in the DuPont™ Tyvek® WRB frame. For an "I-Cut" begin with a horizontal cut across the bottom and the top of the window frame.
- Cut a head flap at a 45° angle to expose 8" of sheathing to allow for head flashing installation.
- Cut two 45° slits extending from the bottom corner up and away from the window opening to expose 6"–8" of sheathing. This will create a flap at each jamb to allow for jamb flashing installation.
- Flip the head flap up to expose the sheathing and temporarily secure with DuPont™ Tyvek® Tape.
- Flip the flaps to the side to expose the sheathing and temporarily secure with DuPont™ Tyvek® Tape.

NOTE: In lieu of temporarily taping, the DuPont™ Tyvek® flap at the window head can be tucked under the DuPont™ Tyvek® WRB frame.

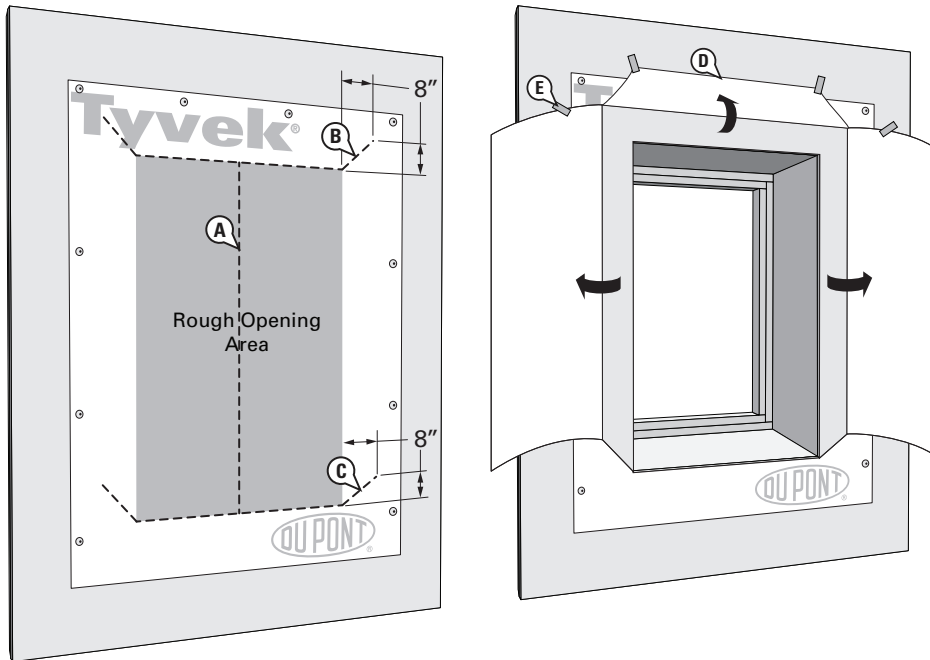

Step 3 – Install DuPont™ FlexWrap™ NF Recessed Window Corner at Sill

- Place FlexWrap™ NF Recessed Window Corner into corner of recess so exposed butyl is against face of recessed window frame and adhere.

NOTE: For double stud window frames, the FlexWrap™ NF Recessed Window Corner should extend a minimum of 2" onto the face of the recessed window frame and cover the seams between the studs. For single stud window frames, the FlexWrap™ NF Recessed Window Corner extending slightly beyond the face of the stud can be fully adhered into framing.

- Remove remaining release paper.
- Adhere exposed butyl to sill and jamb surfaces of recess.
- Place a bead of DuPont™ Residential Sealant or recommended sealant behind the loose triangular flap within the FlexWrap™ NF Recessed Window Corner.
- Press down the loose triangular flap onto the sealant.
- Repeat Steps A-E for opposite side.

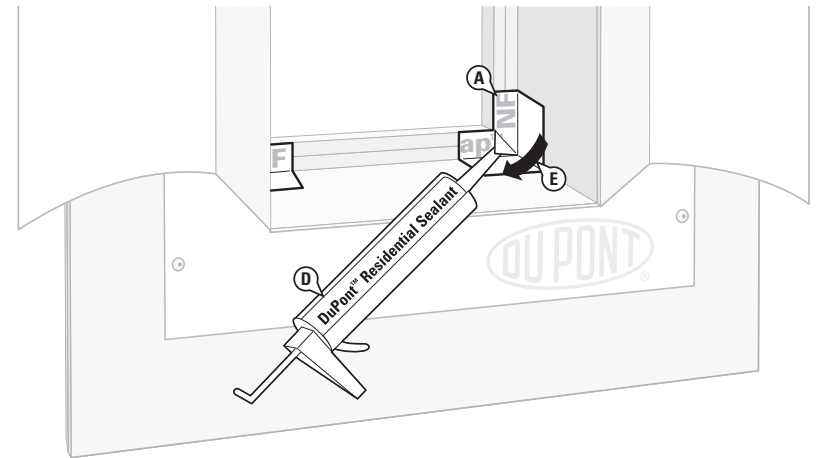

Installation of Integral Flanged Windows in Recessed Openings Greater than 4" Before Water-Resistive Barrier (WRB) Is Installed – Method 1

Step 4 – Install DuPont™ FlexWrap™ NF at Outer Sill of Recessed Opening

- A. Cut FlexWrap™ NF at least 12" LONGER than width of outer sill of recess (S).
- B. Remove wide piece of release paper. Cover horizontal sill by aligning the exposed butyl onto the horizontal surface of outer sill and up jambs (min. 6" on each side).
- C. Remove narrow release paper.
- D. Fan out FlexWrap™ NF at bottom corners onto face of wall. Coverage of FlexWrap™ NF should be a minimum of 2" onto the face of the wall.

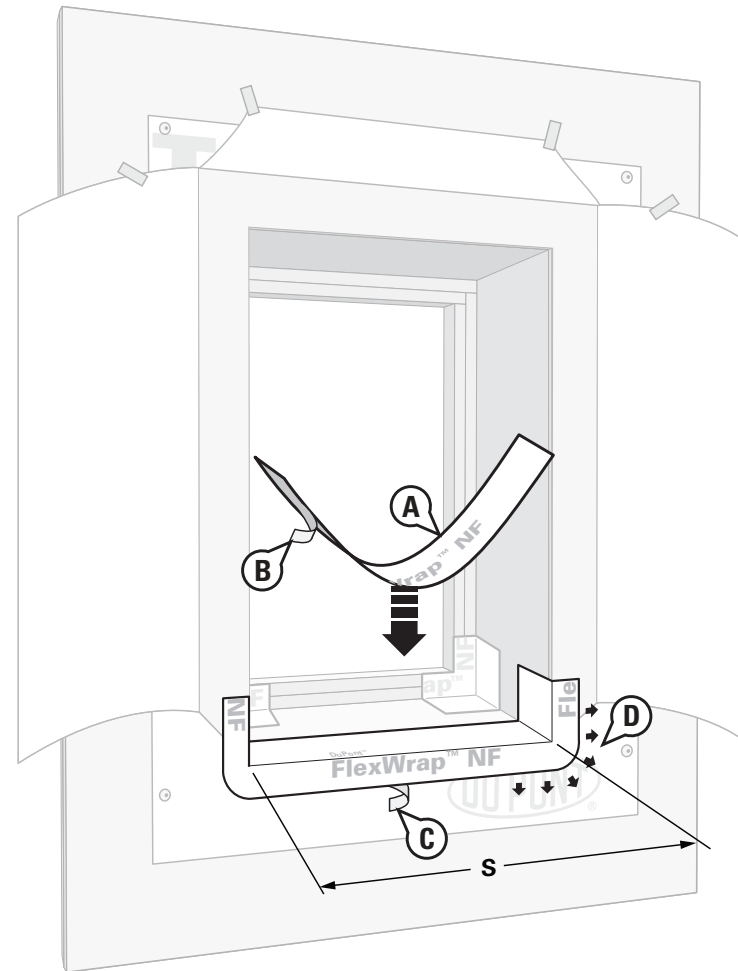

Installation of Integral Flanged Windows in Recessed Openings Greater than 4" Before Water-Resistive Barrier (WRB) Is Installed – Method 1

Step 5 – Install DuPont™ Flashing Tape at Sill of Recess

DuPont™ Flashing Tape will be used at the sill of the recess in this Step to overlap the DuPont™ FlexWrap™ NF at the outer sill and extend onto the face of the stud framing at the inner window sill. The number of layers and product widths can be modified accordingly but all overlaps need to be a minimum of 2". All but the last layer of DuPont™ Flashing Tape will extend 6" min. up each side of the recess jamb walls. The last layer will be the width of the outer rough opening and will extend 2" min. onto the face of the stud framing at the sill of the window.

- A. Cut the first course of DuPont™ Flashing Tape 12" longer than outer sill (S).
- B. Remove the release paper and align on sill to overlap DuPont™ FlexWrap™ NF by 2" and extend up each jamb wall of recess by 6". DuPont™ Flashing Tape should be installed tightly into the corner at the intersection of the recess sill and wall of recess. **NOTE:** The DuPont™ Flashing Tape on the jamb walls will have an angled offset from the window framing in recesses that have a sloped sill.
- C. Adhere exposed butyl to sill of recess and up jamb walls of recess.
- D. If necessary, repeat Step B with appropriate width of DuPont™ Flashing Tape to overlap the first layer of DuPont™ Flashing Tape by 2".
- E. Cut the last layer of DuPont™ Flashing Tape the length of the inner window sill (S), and use appropriate width for a minimum of 2" adhesion of butyl onto the face of the stud framing at the window sill maintaining a 2" overlap onto previous layer. **NOTE:** This dimension will need to be adjusted if the side walls of the recess are tapered.
- F. Fold to create a sharp crease that is aligned with the intersection of the recessed sill and the face of the stud framing. Tear release paper at the fold so exposed butyl can be adhered on to sill of recess. Do not cut release paper with sharp object as this may damage the butyl and compromise protection provided by the DuPont™ Flashing Tape.
- G. Adhere exposed butyl on sill of recess and tight into the intersection of recessed sill and face of stud framing.
- H. Remove second release paper and adhere exposed butyl onto face of stud framing.
- I. Apply a continuous bead of DuPont™ Residential Sealant or recommended sealant along the edge of the overlap between the DuPont™ Flashing Tape and the DuPont™ FlexWrap™ NF.

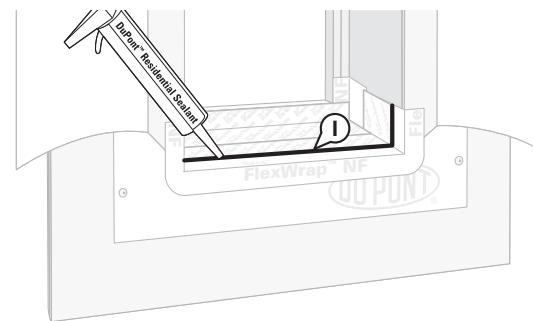
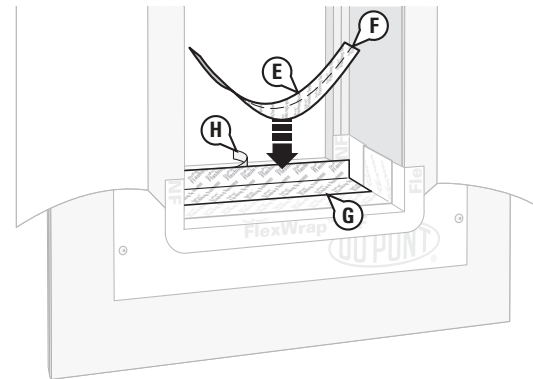
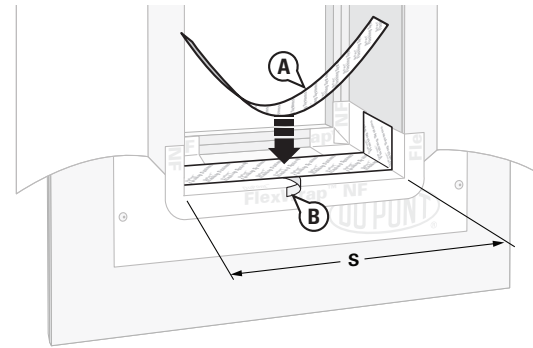

Installation of Integral Flanged Windows in Recessed Openings Greater than 4" Before Water-Resistive Barrier (WRB) Is Installed – Method 1

Step 6 – Install DuPont™ FlexWrap™ NF in Rough Opening at Sill

A. Cut FlexWrap™ NF at least 12" LONGER than width of inner/recessed sill (S^1).

NOTE: Use 6" wide DuPont™ FlexWrap™ NF for 2" x 4" framing and 9" wide DuPont™ FlexWrap™ NF for 2" x 6" framing.

- B. Remove wide piece of release paper.
- C. Cover sill by aligning FlexWrap™ with inside edge of sill and adhere onto sill and up jambs (min. 6" on each side).
- D. Remove narrow release paper.
- E. Fan out FlexWrap™ NF at bottom corners onto face of recessed window framing. Coverage of FlexWrap™ NF should be a minimum of 2" onto the face of the window frame.

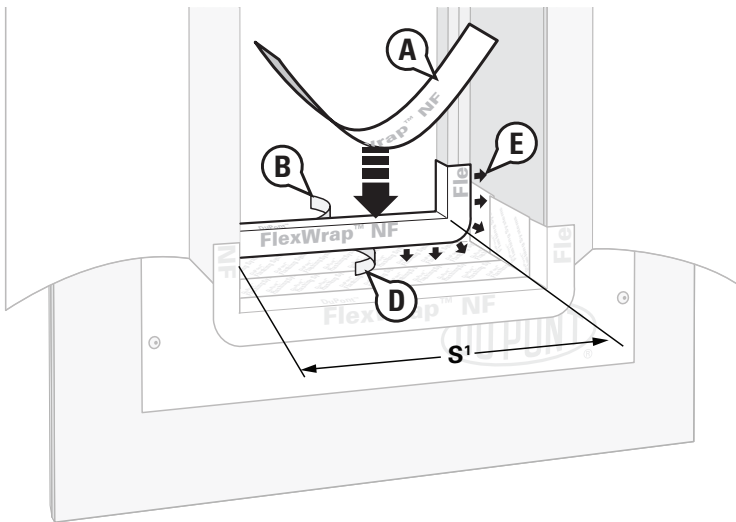

Step 7 – Install Window

- A. Apply DuPont™ Residential Sealant or recommended sealant on the face of the inner recess framing at jambs and head as shown below. If sealant is applied to the sill, ensure that there are at least two (2) 2" gaps in the sealant bead for every 4' of window to allow for drainage.
- B. Install window per window manufacturer's instructions.

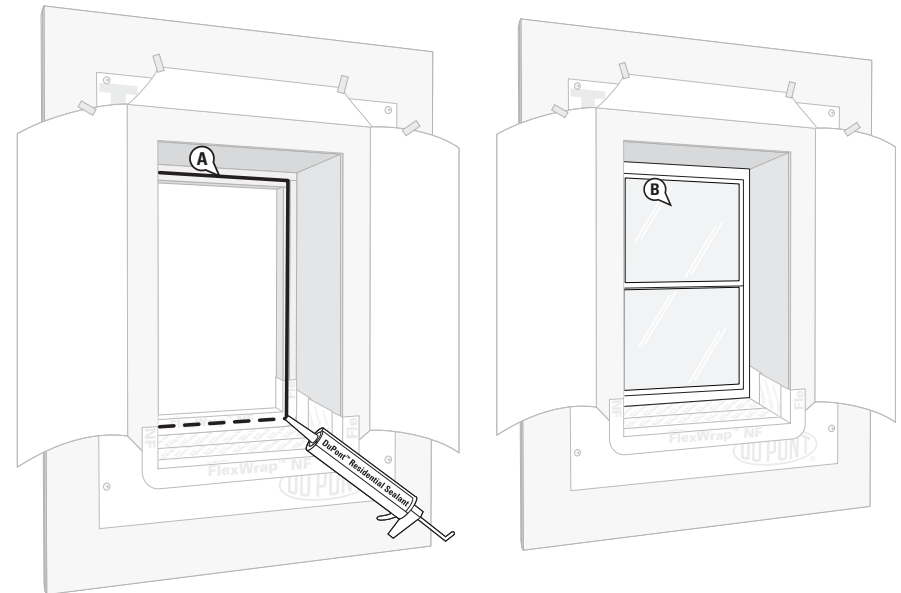

Installation of Integral Flanged Windows in Recessed Openings Greater than 4" Before Water-Resistive Barrier (WRB) Is Installed – Method 1

Step 8 – Install DuPont™ Flashing Tape at Jamb

A. Cut a piece of DuPont™ Flashing Tape 2" LONGER than the length of the outer jamb (J).

NOTE: This dimension will need to be adjusted accordingly to accommodate the slope in the sill. Use appropriate width of DuPont™ Flashing Tape to overlap window flange, adhere onto face of stud frame, and extend a minimum of 2" onto jamb wall of recess.

B. Fold lengthwise to create a sharp crease in release paper that is aligned with the intersection of the face of the stud framing and jamb wall of recess.

C. Starting at the bottom, cut a 2" vertical slit in the DuPont™ Flashing Tape along the crease. This will be used to create the DuPont™ Flashing Tape corner in Steps F and H shown below.

D. Remove the first piece of release paper to expose the butyl that will be installed onto the window flange by tearing along the crease. **Leave the release paper on the 2" flap created in Step C.** Do not cut release paper with sharp object as this could result in damage to butyl and compromise protection provided by the DuPont™ Flashing Tape.

E. Starting at top corner of recess, adhere exposed butyl adhesive onto window flange and face of stud framing.

F. Remove the release paper from the corner flap in the DuPont™ Flashing Tape, created in Step C, and adhere the flap to the sill. **NOTE:** Keeping the remaining release papers intact will make the flashing more rigid to help maneuver the flashing into the corners.

G. Once the butyl is adhered to the window flange, face of stud framing, and sill, remove the remaining release paper – **leaving the release paper on the other 2" flap created in Step C.** The flashing can now be adhered tightly into the inside corner created by the stud framing and jamb wall of the recess.

H. Remove the release paper from the second corner flap and adhere over the first flap.

I. Apply DuPont™ Residential Sealant, or recommended sealant, to the interfaces as shown.

J. Repeat Steps A through I for opposite jamb.

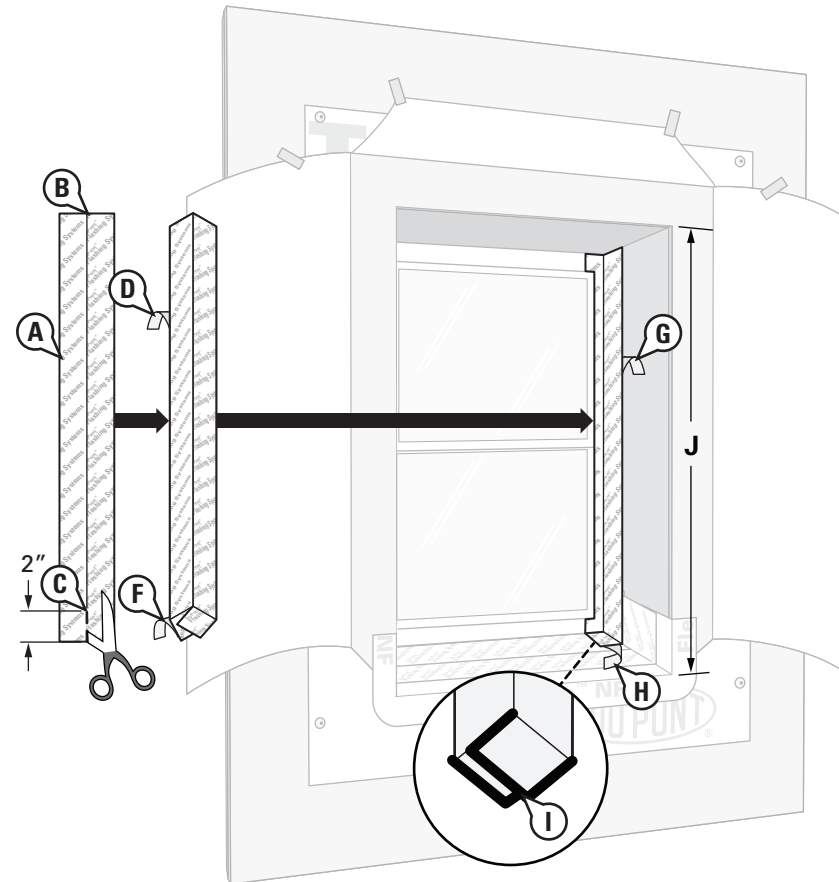

Installation of Integral Flanged Windows in Recessed Openings Greater than 4" Before Water-Resistive Barrier (WRB) Is Installed – Method 1

Step 9 – Install DuPont™ FlexWrap™ NF Recessed Window Corners at Head

- Install DuPont™ FlexWrap™ NF Recessed Window Corners into the upper corner of the window rough opening with exposed butyl adhered onto the window flanges in a similar manner used for lower corner pieces (See Step 3).
- Remove remaining release paper and adhere exposed butyl onto head and jamb walls of recess.
- Place a bead of DuPont™ Residential Sealant or recommended sealant inside the corner flap behind the loose triangular flap of the corner piece.
- Press the loose triangular flap onto the sealant in the corner piece.
- Repeat Steps A through D for opposite corner.

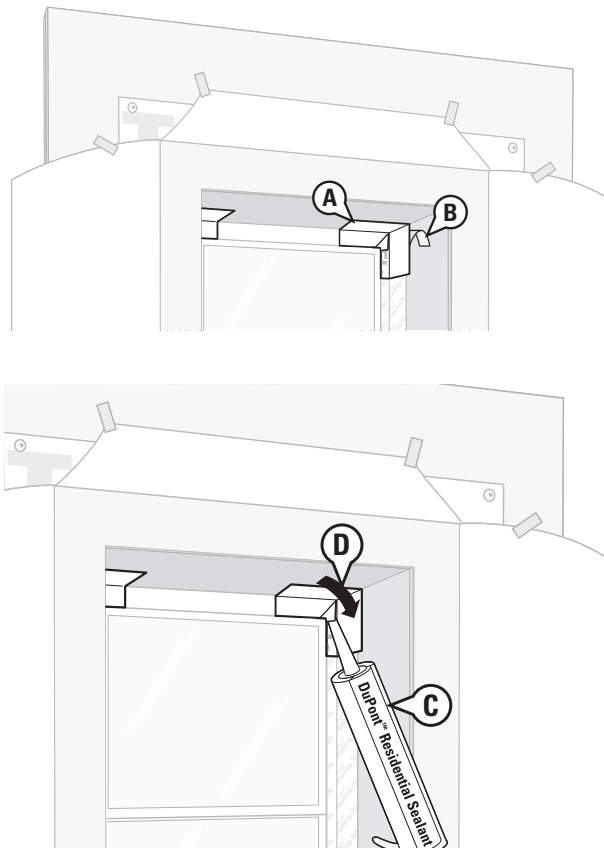

Step 10 – Install DuPont™ Flashing Tape at Head

- Cut a piece of DuPont™ Flashing Tape the length of the inner head rough opening "H". Use appropriate width of DuPont™ Flashing Tape to overlap window flange, adhere onto face of stud frame, and extend a minimum of 2" onto ceiling of recess.
- Fold lengthwise to create a sharp crease in the release paper that is aligned with the intersection of the face of the stud framing and ceiling of recess.
- Remove release paper by tearing along fold to expose butyl for installation onto the window flange and face of stud framing. Do not cut release paper with sharp object as this could result in damage to butyl and compromise protection provided by the DuPont™ Flashing Tape.
- Adhere onto window flange and tightly into corner of intersection between face of stud framing and ceiling of recess.
- Remove remaining release paper and adhere onto ceiling of recess.

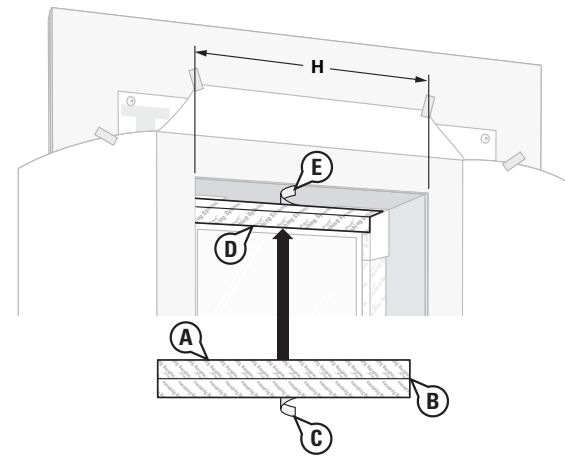

Installation of Integral Flanged Windows in Recessed Openings Greater than 4" Before Water-Resistive Barrier (WRB) Is Installed – Method 1

Step 11 – Install Jamb Flaps onto Wall of Recess

- Trim bottom and side edges of jamb flap if necessary. Flap should overlap jamb flashing by 2" and to allow for sealing using DuPont™ Tyvek® Tape.
- Fasten DuPont™ Tyvek® WRB to jamb walls of recess. Do not fasten within 3" of vertical and horizontal borders of flap.
- Trim lower edges of jamb flaps to allow sealing at bottom of recess jamb walls.
- Install DuPont™ Flashing Tape along the bottom edges of flap inside recess and onto face of wall.
- Install DuPont™ Flashing Tape along the bottom angled cuts in in the DuPont™ Tyvek® WRB making sure to overlap with DuPont™ Flashing Tape at lower edges of flaps inside recess.
- Seal vertical edge of flap with DuPont™ Tyvek® Tape.
- Repeat Steps A through F for opposite jamb.

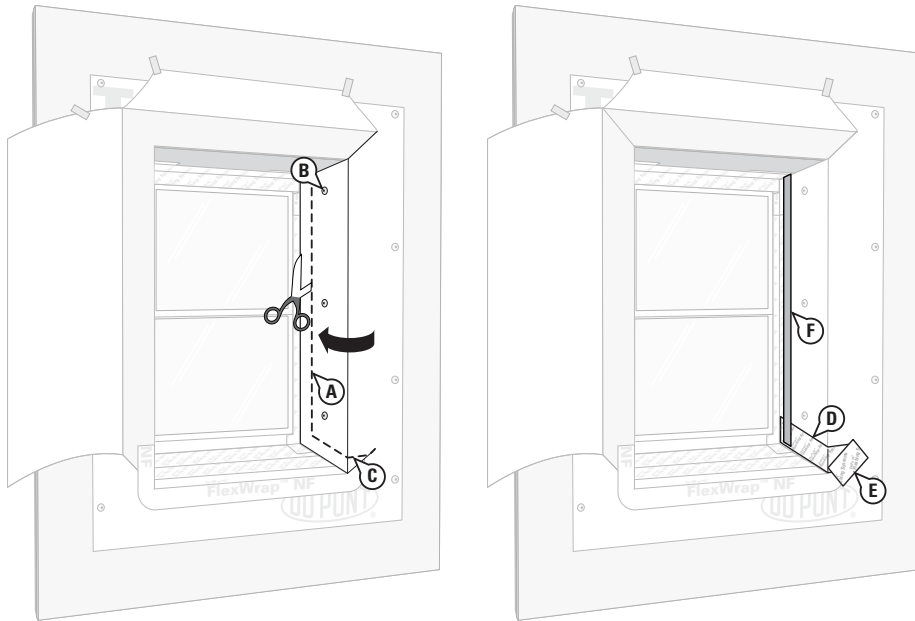

Step 12 – Install DuPont™ Tyvek® WRB at Recess Ceiling

- Cut a piece of DuPont™ Tyvek® WRB 12" longer than recess rough opening (H) and width 1–2" less than depth of the recess.
- Fasten at recess ceiling so outer edge is aligned with face of the wall and 6" overlaps onto jamb walls. Do not fasten within 3" of edges so DuPont™ Tyvek® WRB can be sealed to head flashing using DuPont™ Tyvek® Tape without fastener interference.
- Fasten at jamb walls of recess. Do not fasten within 3" of edges.
- Seal all inside edges using DuPont™ Tyvek® Tape.

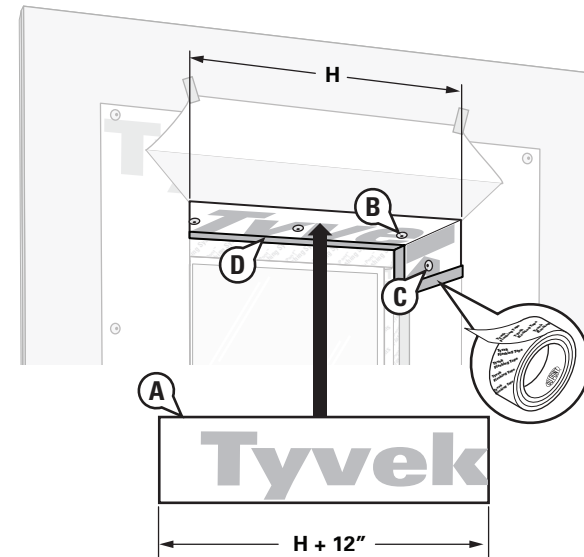

Installation of Integral Flanged Windows in Recessed Openings Greater than 4" Before Water-Resistive Barrier (WRB) Is Installed – Method 1

Step 13 – Install DuPont™ FlexWrap™ NF in Rough Opening at Head

- Cut DuPont™ FlexWrap™ NF at least 12" longer than width of recess rough opening (H).
- Remove wide piece of release paper.
- Align the exposed butyl with the outside edge of the wall and adhere to the horizontal surface at inner ceiling of head recess and down inner jamb walls by 6".
- Remove second release paper.
- Fan out FlexWrap™ NF at top corners of recess opening with minimum coverage of 2" onto the face of wall.

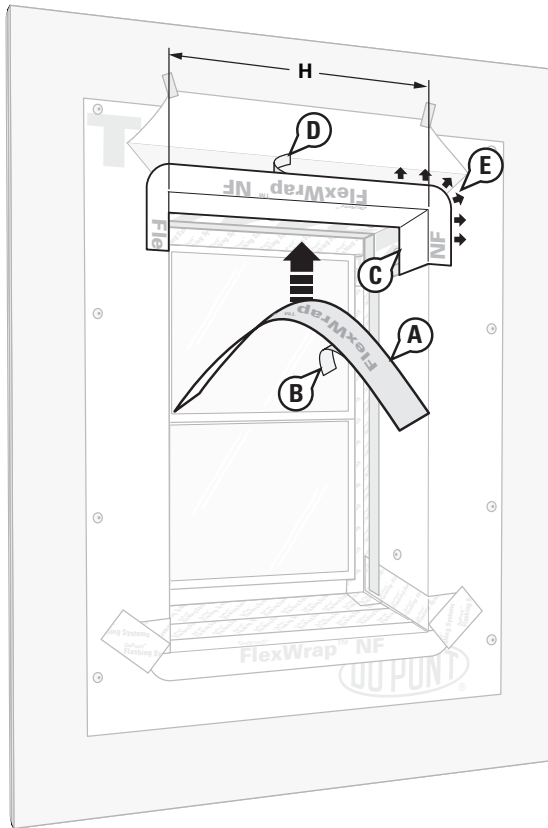

Step 14 – Secure Upper Flap

- Flip down upper flap of DuPont™ Tyvek® WRB so it lays flat across DuPont™ FlexWrap™ NF at head of outer recess.
- Cut ~1" strip of the DuPont™ Tyvek® WRB at lower horizontal edge of head flap.
- Continuous tape seams as shown with DuPont™ Flashing Tape. Skip-taping at head is acceptable if an air barrier is not required or if additional drainage is desired.
- Install mechanical fasteners through the flashing at the head flap.

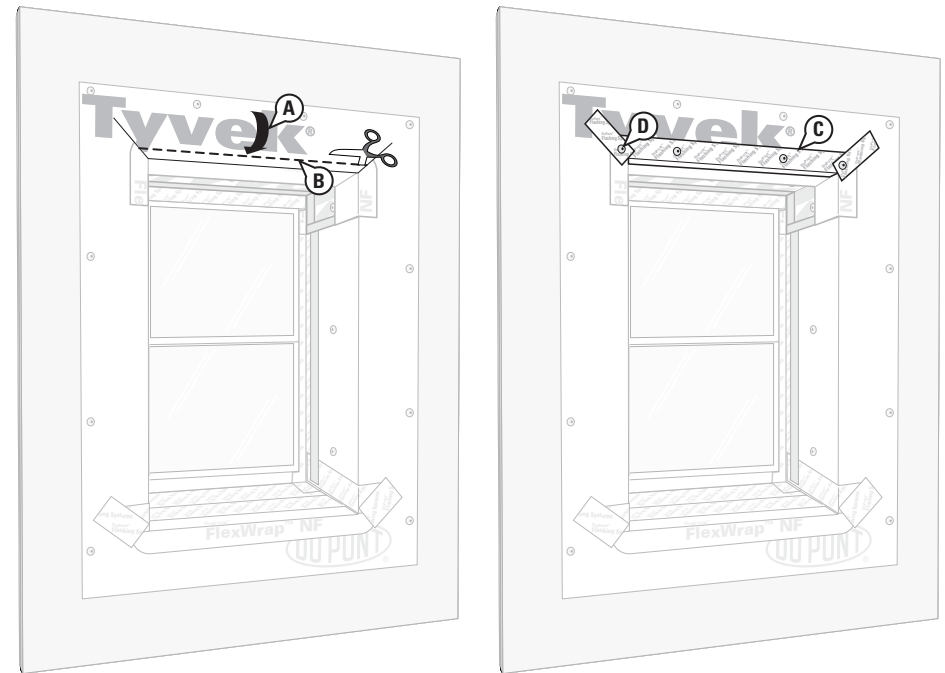

Installation of Integral Flanged Windows in Recessed Openings Greater than 4" Before Water-Resistive Barrier (WRB) Is Installed – Method 1

Step 15 – Seal Interior Opening

Install DuPont™ Residential Sealant or recommended sealant (and backer rod as necessary) around the window opening at the interior. It is also acceptable to use DuPont™ Window & Door Foam or recommended foam at the interior cavity of the jambs and head. If foam is used at the sill, recommended sealant should be used at the sill area behind the foam to ensure a proper water seal. The seal created by the sealant (and backer rod as necessary) will also serve as a back dam. DuPont™ Residential Sealant should be tooled flat to allow the natural curing process to create a concave shape. Be sure that the sealant penetrates the grooves of the DuPont™ FlexWrap™ NF.

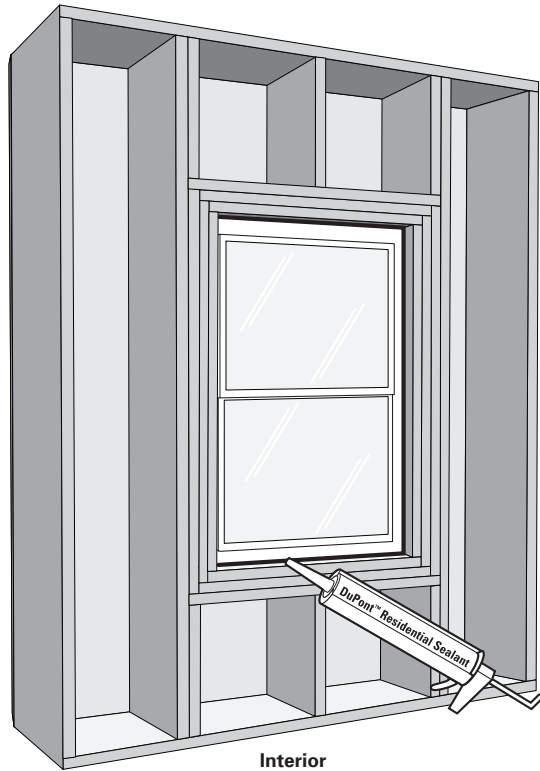

Installation of Integral Flanged Windows in Recessed Openings Greater than 4" Before Water-Resistive Barrier (WRB) Is Installed – Method 1

Step 16 – Install and Integrate DuPont™ Tyvek® WRB

- Install the DuPont™ Tyvek® WRB according to the DuPont™ Tyvek® Air- and Water-Resistive Barrier Installation Guidelines. Do not install fasteners within 8" of the rough opening along jambs and head and within 12" along the sill.
- Mark a perimeter box 6" away from the rough opening sill, jambs and head.
- Cut the DuPont™ Tyvek® WRB along perimeter marking to expose window and DuPont™ Tyvek® WRB frame below. Do not cut DuPont™ Tyvek® WRB frame underneath.
- Create 6" horizontal slits in the DuPont™ Tyvek® WRB at each lower corner of the perimeter cut.
- Bring the bottom portion of the DuPont™ Tyvek® WRB frame through the slits so it laps over the top layer of DuPont™ Tyvek® WRB.
- Tape seams at bottom, sides, and top of rough opening using DuPont™ Tyvek® Tape.

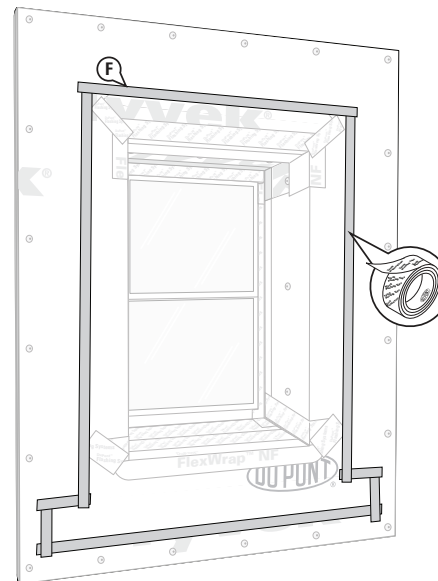
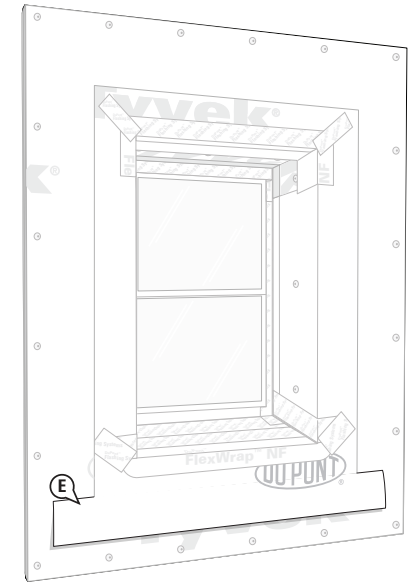
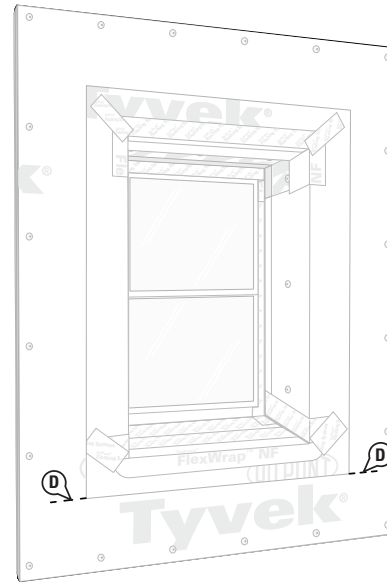
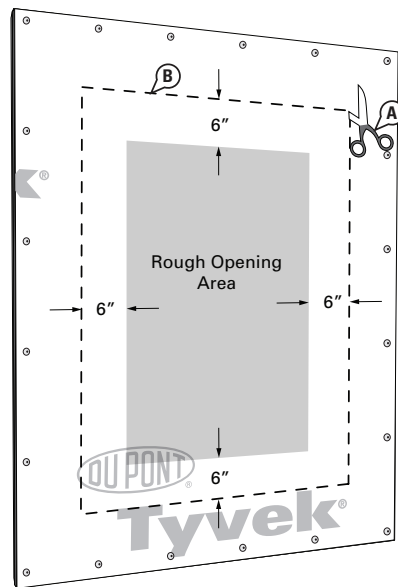
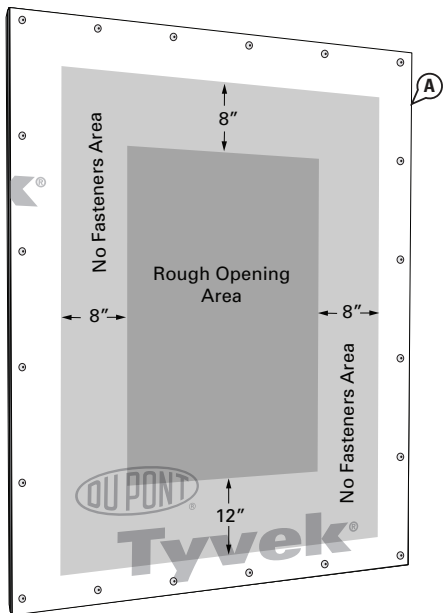

Installation of Integral Flanged Windows in Recessed Openings Greater than 4" Before Water-Resistive Barrier (WRB) Is Installed – Method 2

Installation Method 2: Depth of the Recess is Greater Than 1/2 the Width of the Recess

Method 2: This method must be used when the depth of the recess is greater than 1/2 the width of the recess which requires additional strips of DuPont™ Tyvek® WRB to cover jamb walls of the recess. If the depth of the recess is <1/2 the width of recess, Method 2 can be used as an optional method in place of Method 1.

Step 1 – Install DuPont™ Tyvek® WRB Frame Around Window Rough Opening

Installation of DuPont™ Tyvek® WRB frame prior to window installation is necessary for proper shingling and integration with the DuPont™ Tyvek® WRB which will be installed after the window (see Step 16).

- Cut a piece of DuPont™ Tyvek® WRB that is 24" wider and 24" taller than the window rough opening to allow a 12" width around all sides.
- Center the piece of DuPont™ Tyvek® WRB over the rough opening and fasten along the sides and across the top using DuPont™ Tyvek® Wrap Caps or recommended fastening system. Fasteners should not be installed within 10" of the edge of the rough opening, and no fasteners should be installed within 8" of the bottom edge of the DuPont™ Tyvek® WRB.
- Cut an opening using an "O" cut at the perimeter of the rough opening along the dashed indicated lines to create a DuPont™ Tyvek® WRB frame around the window. (Ensure that the DuPont™ Tyvek® WRB frame is cut flush with the sheathing and is not wrapped into the rough opening).

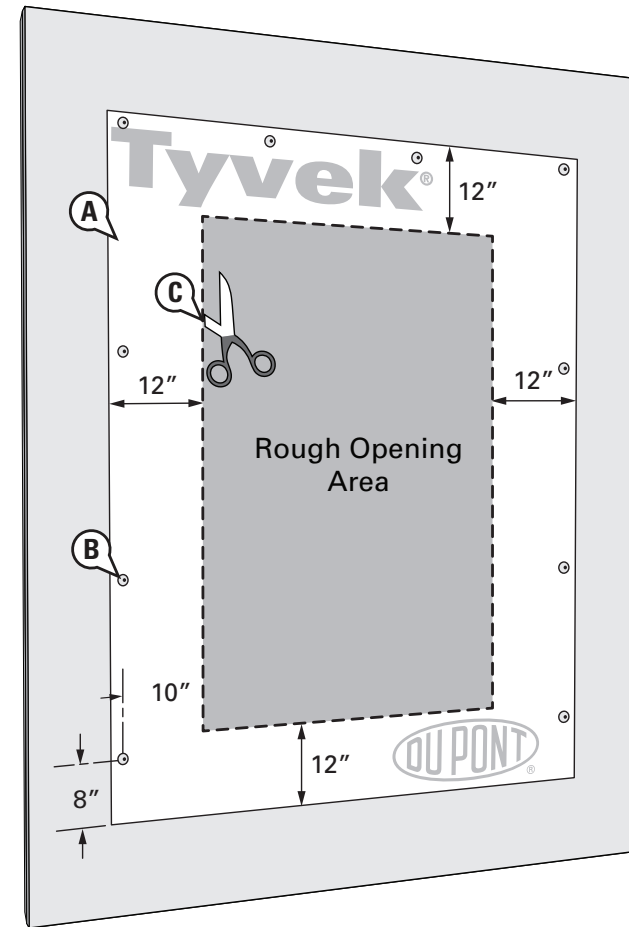

Installation of Integral Flanged Windows in Recessed Openings Greater than 4" Before Water-Resistive Barrier (WRB) Is Installed – Method 2

Step 2 – Prepare DuPont™ Tyvek® WRB Frame for Window Installation

- Cut two 45 degree slits extending a minimum of 8" up and away from the top corners of the rough opening. This will create a flap to expose sheathing or framing members to allow head flashing installation.
- Flip the head flap up to expose the sheathing and temporarily secure with DuPont™ Tyvek™ Tape.
- Temporarily secure the DuPont™ Tyvek® WRB frame with DuPont™ Tyvek® Tape around rough opening before flashing is installed to help facilitate flashing installation.

NOTE: In lieu of temporarily taping, the DuPont™ Tyvek® flap at the window head can be tucked under the DuPont™ Tyvek® WRB frame.

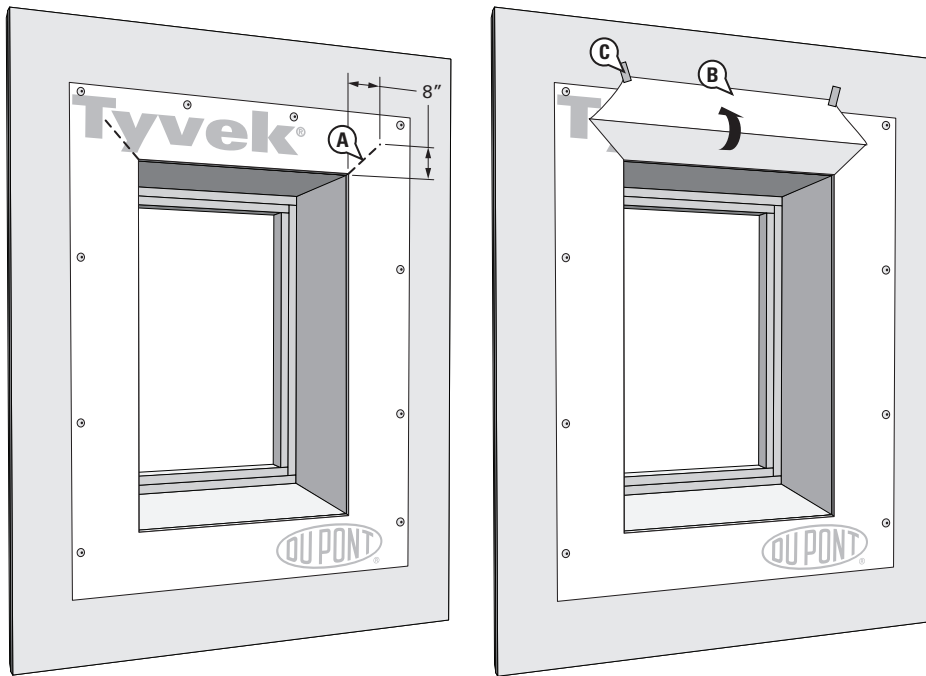

Step 3 – Install DuPont™ FlexWrap™ NF Recessed Window Corner at Sill

- Place FlexWrap™ NF Recessed Window Corner into corner of recess so exposed butyl is against face of recessed window frame and adhere.

NOTE: For double stud window frames, the FlexWrap™ NF Recessed Window Corner should extend a minimum of 2" onto the face of the recessed window frame and cover the seams between the studs. For single stud window frames, the FlexWrap™ NF Recessed Window Corner extending slightly beyond the face of the stud can be fully adhered into framing.

- Remove remaining release paper.
- Adhere exposed butyl to sill and jamb surfaces of recess.
- Place a bead of DuPont™ Residential Sealant or recommended sealant behind the loose triangular flap within the FlexWrap™ NF Recessed Window Corner.
- Press down the loose triangular flap onto the sealant.
- Repeat Steps A-E for opposite side.

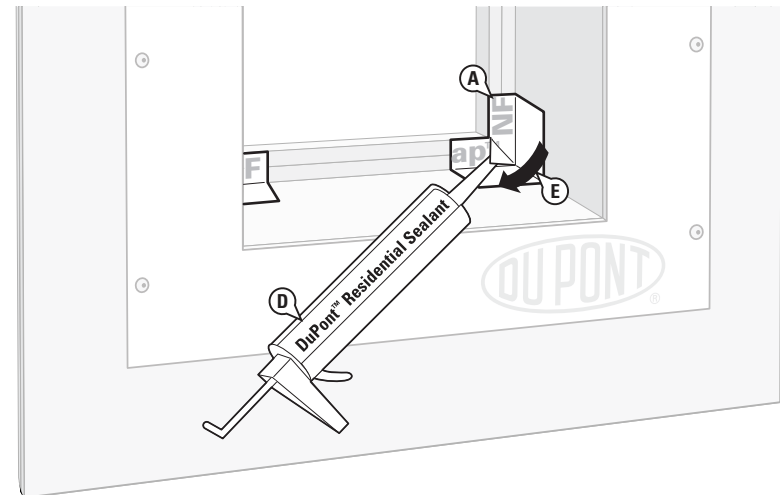

Installation of Integral Flanged Windows in Recessed Openings Greater than 4" Before Water-Resistive Barrier (WRB) Is Installed – Method 2

Step 4 – Install DuPont™ FlexWrap™ NF at Outer Sill of Recessed Opening

- A. Cut FlexWrap™ NF at least 12" LONGER than width of outer sill of recess (S).
- B. Remove wide piece of release paper. Cover horizontal sill by aligning the exposed butyl onto the horizontal surface of outer sill and up jambs (min. 6" on each side).
- C. Remove narrow release paper.
- D. Fan out FlexWrap™ NF at bottom corners onto face of wall. Coverage of FlexWrap™ NF should be a minimum of 2" onto the face of the wall.

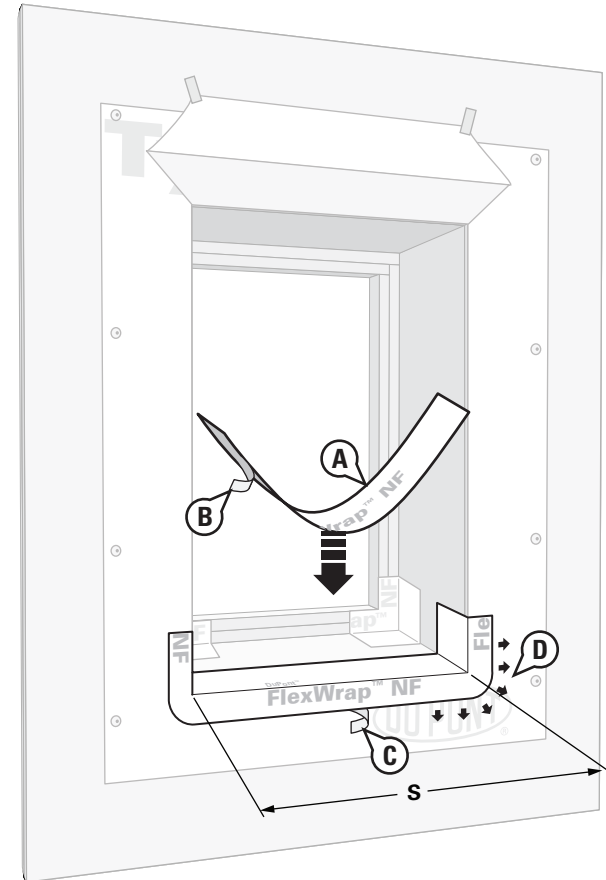

Installation of Integral Flanged Windows in Recessed Openings Greater than 4" Before Water-Resistive Barrier (WRB) Is Installed – Method 2

Step 5 – Install DuPont™ Flashing Tape at Sill of Recess

DuPont™ Flashing Tape will be used at the sill of the recess in this Step to overlap the DuPont™ FlexWrap™ NF at the outer sill and extend onto the face of the stud framing at the inner window sill. The number of layers and product widths can be modified accordingly but all overlaps need to be a minimum of 2". All but the last layer of DuPont™ Flashing Tape will extend 6" min. up each side of the recess jamb walls. The last layer will be the width of the outer rough opening and will extend 2" min. onto the face of the stud framing at the sill of the window.

- A. Cut the first course of DuPont™ Flashing Tape 12" longer than outer sill (S).
- B. Remove the release paper and align on sill to overlap DuPont™ FlexWrap™ NF by 2" and extend up each jamb wall of recess by 6". DuPont™ Flashing Tape should be installed tightly into the corner at the intersection of the recess sill and wall of recess. **NOTE:** The DuPont™ Flashing Tape on the jamb walls will have an angled offset from the window framing in recesses that have a sloped sill.
- C. Adhere exposed butyl to sill and up jamb walls of recess.
- D. If necessary, repeat Step B with appropriate width of DuPont™ Flashing Tape to overlap the first layer of DuPont™ Flashing Tape by 2".
- E. Cut the last layer of DuPont™ Flashing Tape the length of the inner window sill (S), and use appropriate width for a minimum of 2" adhesion of butyl onto the face of the stud framing at the window sill maintaining a 2" overlap onto previous layer. **NOTE:** This dimension will need to be adjusted if the side walls of the recess are tapered.
- F. Fold to create a sharp crease that is aligned with the intersection of the recessed sill and the face of the stud framing. Tear release paper at the fold so exposed butyl can be adhered on to sill of recess. Do not cut release paper with sharp object as this may damage the butyl and compromise protection provided by the DuPont™ Flashing Tape.
- G. Adhere exposed butyl on sill of recess and tight into the intersection of recessed sill and face of stud framing.
- H. Remove second release paper and adhere exposed butyl onto face of stud framing.
- I. Apply a continuous bead of DuPont™ Residential Sealant or recommended sealant along the face of the overlap between the DuPont™ Flashing Tape and the DuPont™ FlexWrap™ NF.

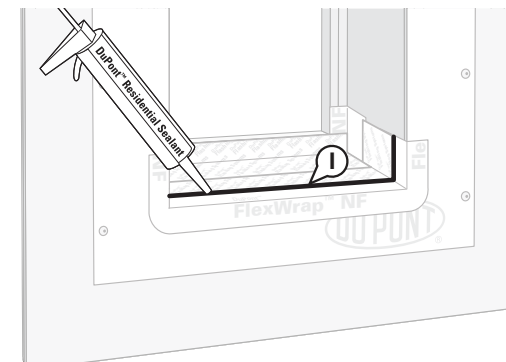
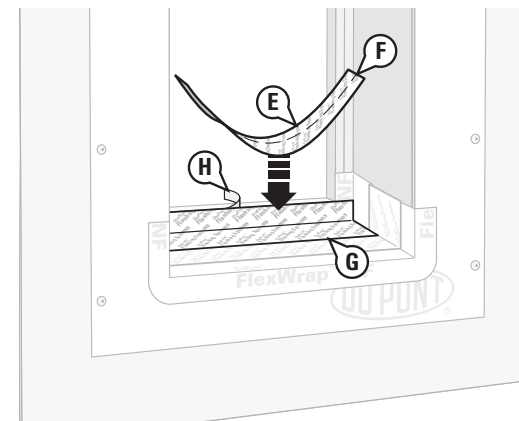
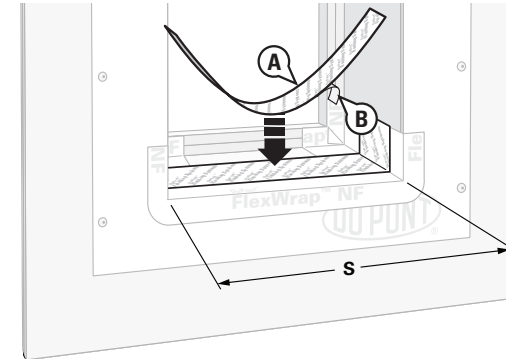

Installation of Integral Flanged Windows in Recessed Openings Greater than 4" Before Water-Resistive Barrier (WRB) Is Installed – Method 2

Step 6 – Install DuPont™ FlexWrap™ NF in Rough Opening at Sill

A. Cut FlexWrap™ NF at least 12" LONGER than width of inner/recessed sill (S¹).

NOTE: Use 6" wide DuPont™ FlexWrap™ NF for 2" x 4" framing and 9" wide DuPont™ FlexWrap™ NF for 2" x 6" framing.

- B. Remove wide piece of release paper.
- C. Cover sill by aligning FlexWrap™ with inside edge of sill and adhere onto sill and up jambs (min. 6" on each side).
- D. Remove narrow release paper.
- E. Fan out FlexWrap™ NF at bottom corners onto face of recessed window framing. Coverage of FlexWrap™ NF should be a minimum of 2" onto the face of the window frame.

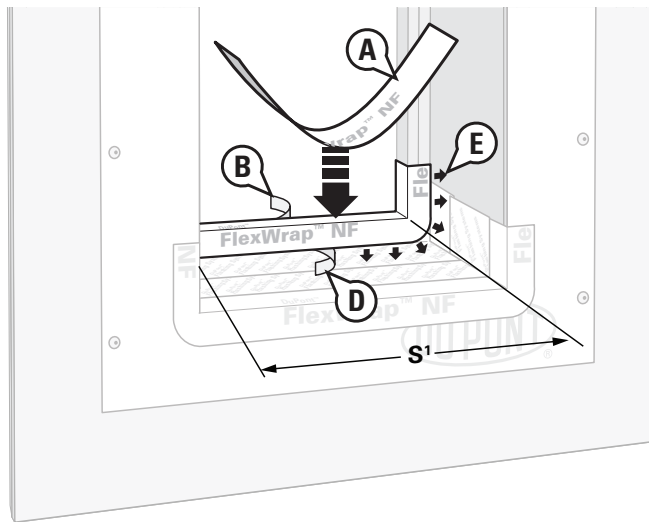

Step 7 – Install Window

- A. Apply DuPont™ Residential Sealant or recommended sealant on the face of the inner recess framing at jambs and head as shown below. If sealant is applied to the sill, ensure that there are at least two (2) 2" gaps in the sealant bead for every 4' of window to allow for drainage.
- B. Install window per window manufacturer's instructions.

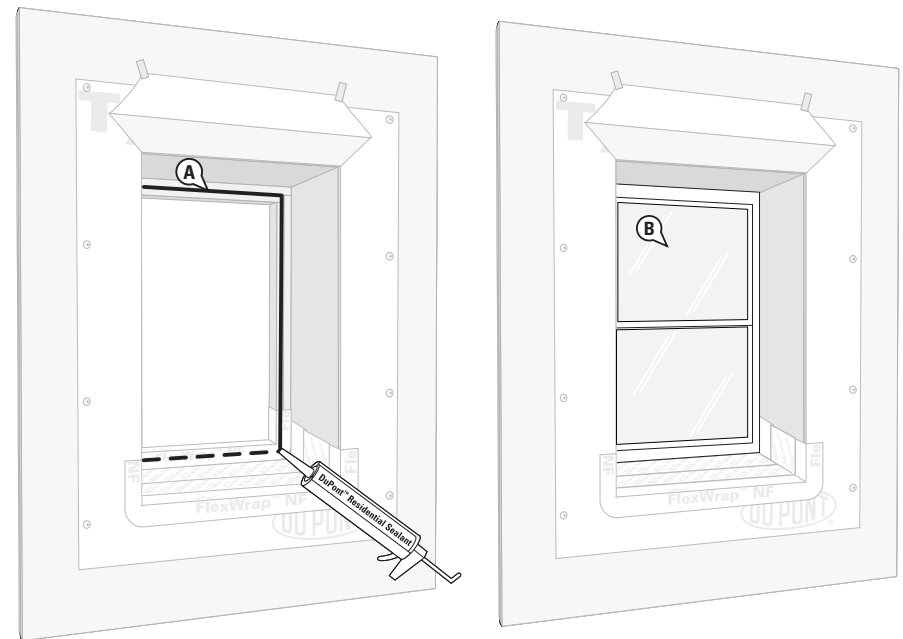

Installation of Integral Flanged Windows in Recessed Openings Greater than 4" Before Water-Resistive Barrier (WRB) Is Installed – Method 2

Step 8 – Install DuPont™ Flashing Tape at Jamb

A. Cut a piece of DuPont™ Flashing Tape 2" LONGER than the length of the outer jamb (J).

NOTE: This dimension will need to be adjusted accordingly to accommodate the slope in the sill. Use appropriate width of DuPont™ Flashing Tape to overlap window flange, adhere onto face of stud frame, and extend a minimum of 2" onto jamb wall of recess.

B. Fold lengthwise to create a sharp crease in release paper that is aligned with the intersection of the face of the stud framing and jamb wall of recess.

C. Starting at the bottom, cut a 2" vertical slit in the DuPont™ Flashing Tape along the crease. This will be used to create the DuPont™ Flashing Tape corner in Steps F and H shown below.

D. Remove the first piece of release paper to expose the butyl that will be installed onto the window flange by tearing along the crease. **Leave the release paper on the 2" flap created in Step C.** Do not cut release paper with sharp object as this could result in damage to butyl and compromise protection provided by the DuPont™ Flashing Tape.

E. Starting at top corner of recess, adhere exposed butyl adhesive onto window flange and face of stud framing.

F. Remove the release paper from the corner flap in the DuPont™ Flashing Tape, created in Step C, and adhere the flap to the sill. **NOTE:** Keeping the remaining release papers intact will make the flashing more rigid to help maneuver the flashing into the corners.

G. Once the butyl is adhered to the window flange, face of stud framing, and sill, remove the remaining release paper – **leaving the release paper on the other 2" flap created in Step C.** The flashing can now be adhered tightly into the inside corner created by the stud framing and jamb wall of the recess.

H. Remove the release paper from the second corner flap and adhere over the first flap.

I. Apply DuPont™ Residential Sealant, or recommended sealant, to the interfaces as shown.

J. Repeat Steps A through I for opposite jamb.

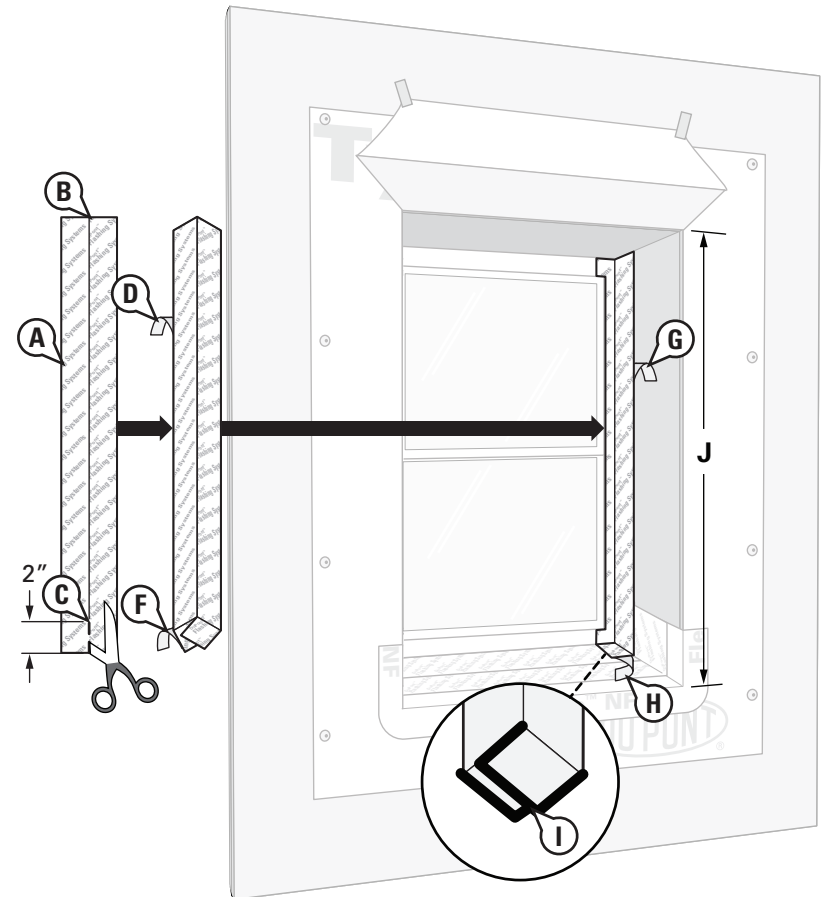

Installation of Integral Flanged Windows in Recessed Openings Greater than 4" Before Water-Resistive Barrier (WRB) Is Installed – Method 2

Step 9 – Install DuPont™ FlexWrap™ NF Recessed Window Corners at Head

- Install DuPont™ FlexWrap™ NF Recessed Window Corners into the upper corner of the window rough opening with exposed butyl adhered onto the window flanges in a similar manner used for lower corner pieces (See Step 3).
- Remove remaining release paper and adhere exposed butyl onto head and jamb walls of recess.
- Place a bead of DuPont™ Residential Sealant or recommended sealant inside the corner flap behind the loose triangular flap of the corner piece.
- Press the loose triangular flap onto the sealant in the corner piece.
- Repeat Steps A through D for opposite corner.

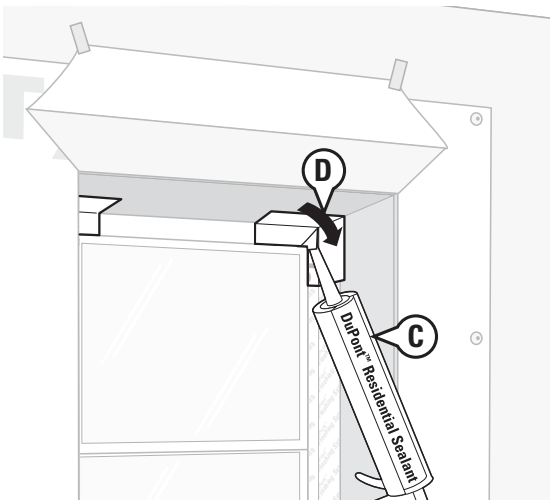
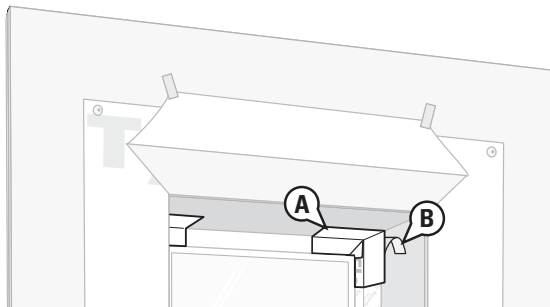

Step 10 – Install DuPont™ Flashing Tape at Head

- Cut a piece of DuPont™ Flashing Tape the length of the head rough opening "H". Use appropriate width of DuPont™ Flashing Tape to overlap window flange, adhere onto face of stud frame, and extend a minimum of 2" onto ceiling of recess.
- Fold lengthwise to create a sharp crease in the release paper that is aligned with the intersection of the face of the stud framing and ceiling of recess.
- Remove release paper by tearing along fold to expose butyl for installation onto the window flange and face of stud framing. Do not cut release paper with sharp object as this could result in damage to butyl and compromise protection provided by the DuPont™ Flashing Tape.
- Adhere onto window flange and tightly into corner of intersection between face of stud framing and ceiling of recess.
- Remove remaining release paper and adhere onto ceiling of recess.

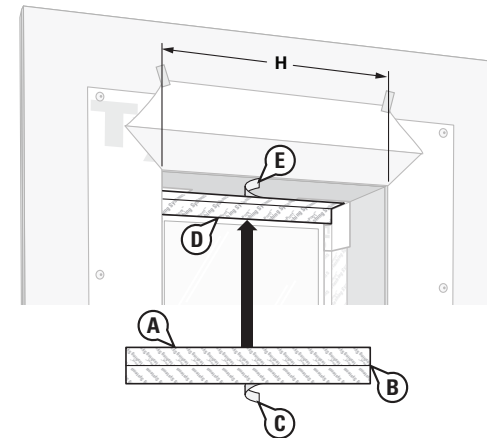

Installation of Integral Flanged Windows in Recessed Openings Greater than 4" Before Water-Resistive Barrier (WRB) Is Installed – Method 2

Step 11 – Install DuPont™ Flashing Tape at Outer Recess Jamb

- Cut a piece of DuPont™ Flashing Tape the length of the jamb rough opening (J) and fold lengthwise creating a sharp crease in the release paper.
- Remove one piece of release paper by tearing along the crease, but do not cut release paper with sharp object as this could result in damage to butyl and compromise protection provided by the DuPont™ Flashing Tape.

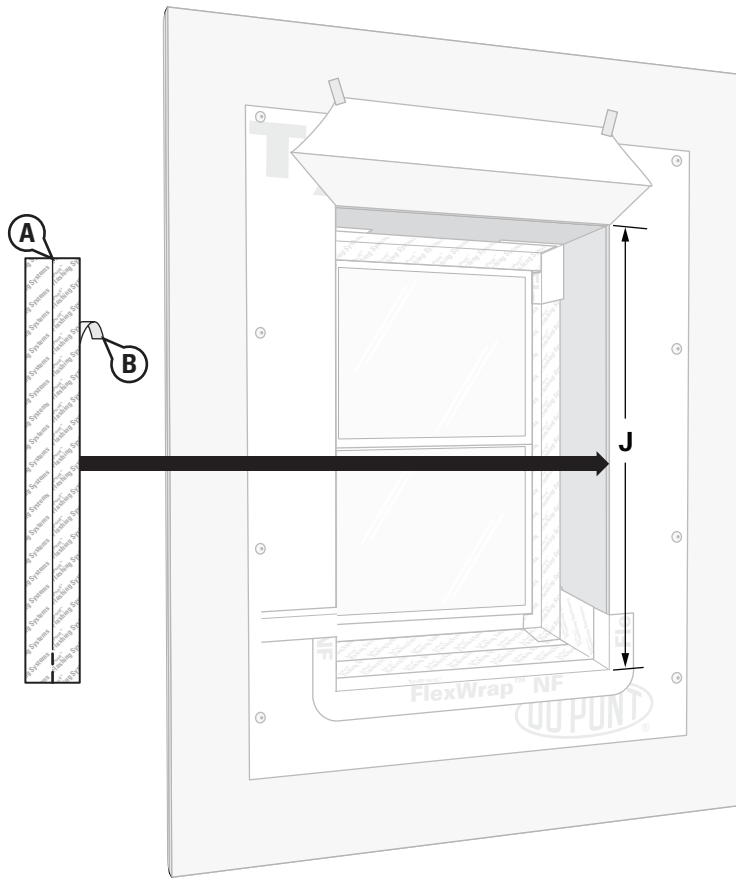

- Adhere exposed butyl onto face of wall so crease is aligned with edge of outer recess rough opening.
- Remove remaining release paper and adhere exposed butyl into rough opening of recess.
- Repeat Steps A-D on opposite side.

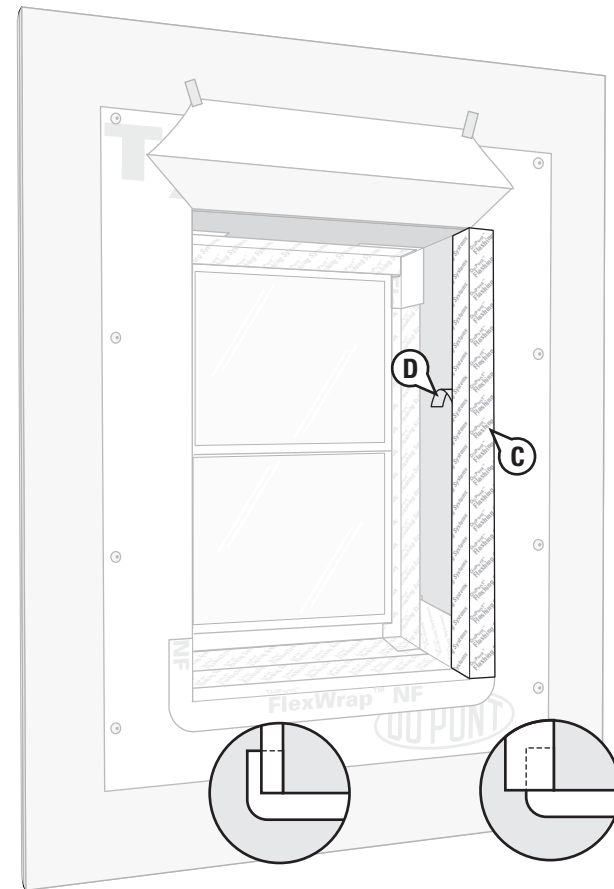

INCORRECT
DuPont™ FlexWrap™ NF
reverse flashed

CORRECT
DuPont™ Flashing Tape
overlaps DuPont™
FlexWrap™ NF

Installation of Integral Flanged Windows in Recessed Openings Greater than 4" Before Water-Resistive Barrier (WRB) Is Installed – Method 2

Step 12 – Install DuPont™ Tyvek® to Jamb Walls of Recess

A. Cut a piece of DuPont™ Tyvek® WRB for each recess jamb that is 2" less than the height (J) and 2–4" less than the depth of the rough opening.

NOTE: These dimensions will need to be adjusted accordingly to accommodate the slope of the recess sill.

B. Align one piece of DuPont™ Tyvek® WRB with top of recess and centered on the vertical wall. Do not fasten within 3" of vertical and horizontal edges so DuPont™ Tyvek® WRB patch can be sealed to flashing using DuPont™ Tyvek® Tape without fastener interference.

C. Install DuPont™ Flashing Tape along the bottom of DuPont™ Tyvek® WRB inside recess.

D. Seal vertical edges of DuPont™ Tyvek® WRB using DuPont™ Tyvek® Tape.

E. Repeat on opposite side.

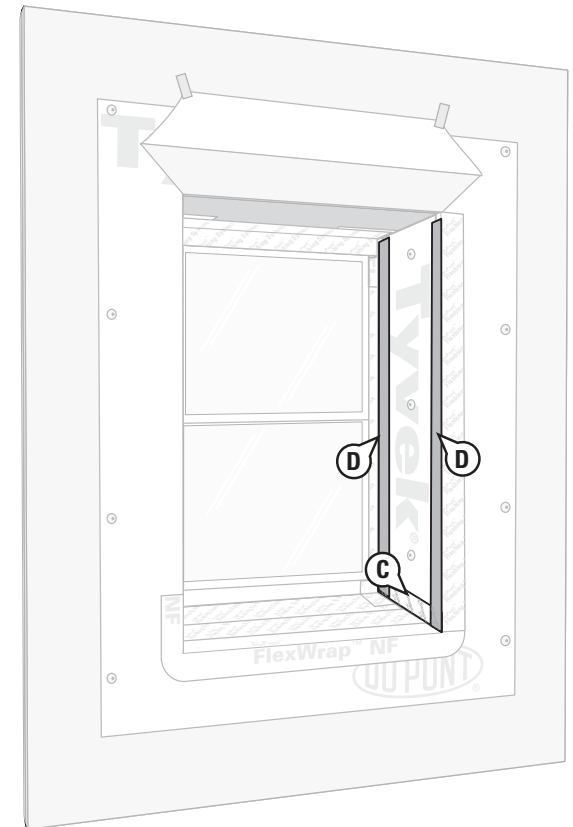
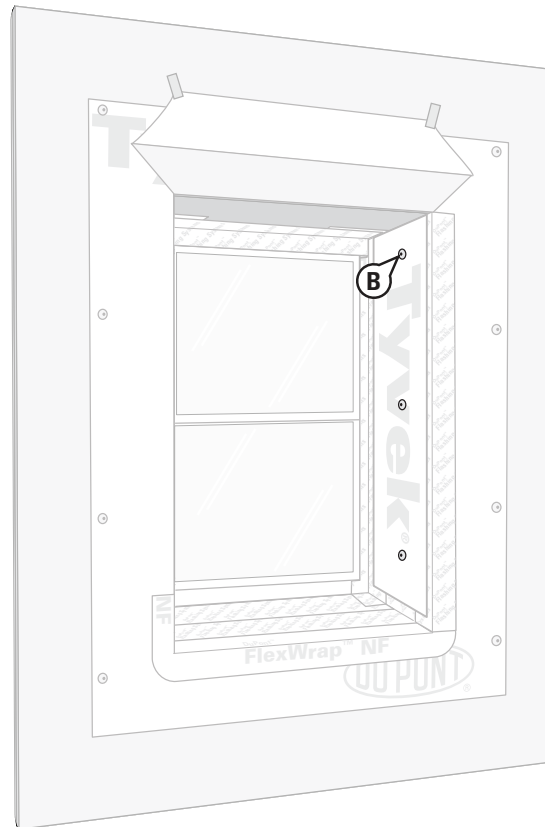
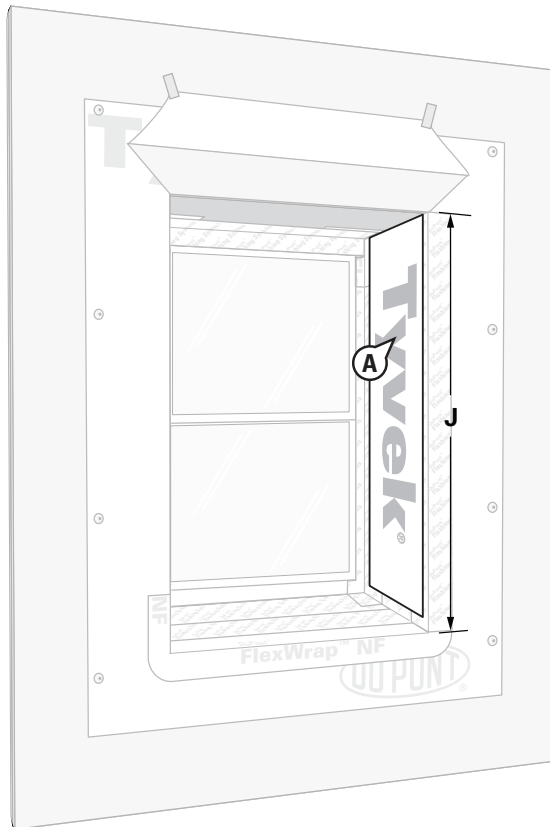

Installation of Integral Flanged Windows in Recessed Openings Greater than 4" Before Water-Resistive Barrier (WRB) Is Installed – Method 2

Step 13 – Install DuPont™ Tyvek® WRB Patch at Recess Ceiling

- Cut a piece of DuPont™ Tyvek® WRB 12" longer than the recess rough opening (H) and a width that is 1–2" less than depth of the recess.
- Fasten at recess ceiling so the outer edge is aligned with the face of the wall with a 6" overlap onto each jamb wall. Do not fasten within 3" of edges, so that the piece of DuPont™ Tyvek® WRB can be sealed to flashing using DuPont™ Tyvek™ Tape without fastener interference.
- Seal all inside edges using DuPont™ Tyvek™ Tape.

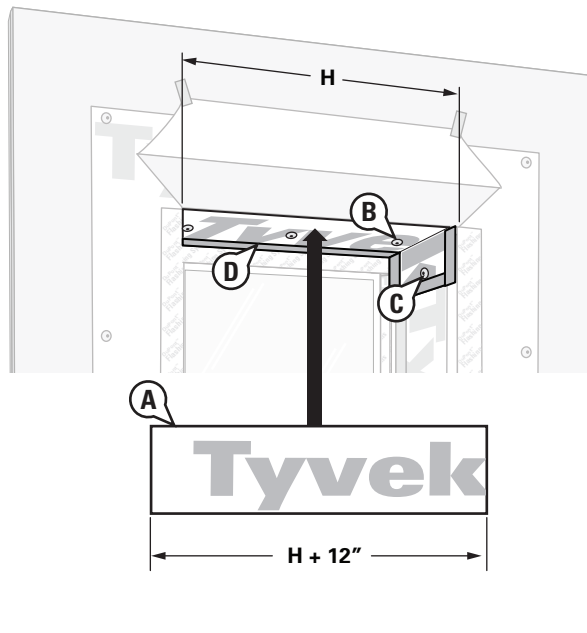

Step 14 – Install DuPont™ FlexWrap™ NF Head of Outer Recess

- Cut DuPont™ FlexWrap™ NF at least 12" longer than width of recess rough opening (H).
- Remove wide piece of release paper.
- Align the exposed butyl with the outside edge of the wall and adhere to the horizontal surface at inner ceiling of head recess and down inner jamb walls by 6".
- Remove second release paper.
- Fan out FlexWrap™ NF at top corners of recess with minimum coverage of 2" onto the face of wall.

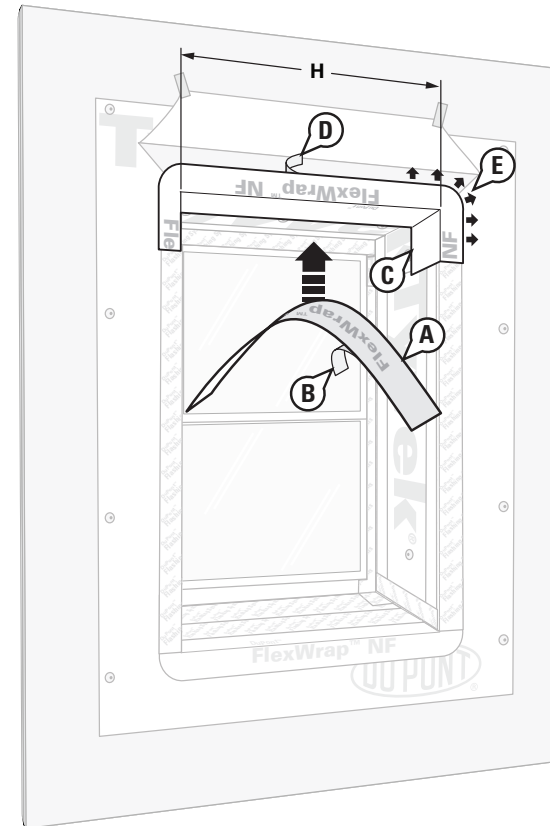

Installation of Integral Flanged Windows in Recessed Openings Greater than 4" Before Water-Resistive Barrier (WRB) Is Installed – Method 2

Step 15 – Secure Upper Flap

- Flip down upper flap of DuPont™ Tyvek® WRB so it lays flat across DuPont™ FlexWrap™ NF at head of outer recess.
- Cut ~1" strip of the DuPont™ Tyvek® WRB at lower horizontal edge of head flap.
- Continuous tape seams as shown with DuPont™ Flashing Tape. Skip-taping at head is acceptable if an air barrier is not required or if additional drainage is desired.
- Install mechanical fasteners through the flashing at the head flap.

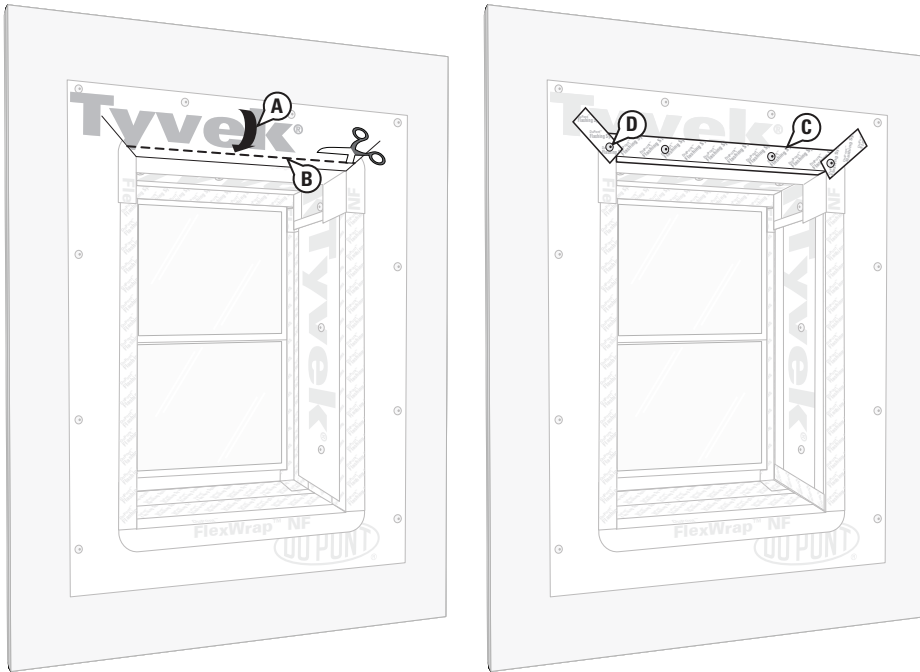

Step 16 – Seal Interior Opening

Install DuPont™ Residential Sealant or recommended sealant (and backer rod as necessary) around the window opening at the interior. It is also acceptable to use DuPont™ Window & Door Foam or recommended foam at the interior cavity of the jambs and head. If foam is used at the sill, recommended sealant should be used at the sill area behind the foam to ensure a proper water seal. The seal created by the sealant (and backer rod as necessary) will also serve as a back dam. DuPont™ Residential Sealant should be tooled flat to allow the natural curing process to create a concave shape. Be sure that the sealant penetrates the grooves of the DuPont™ FlexWrap™ NF.

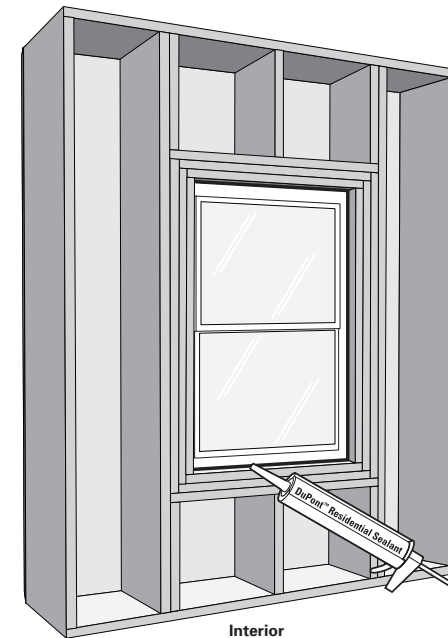

Installation of Integral Flanged Windows in Recessed Openings Greater than 4" Before Water-Resistive Barrier (WRB) Is Installed – Method 2

Step 17 – Install and Integrate DuPont™ Tyvek® WRB

- Install the DuPont™ Tyvek® WRB according to the DuPont™ Tyvek® Air- and Water-Resistive Barrier Installation Guidelines. Do not install fasteners within 8" of the rough opening along jambs and head and within 12" along the sill.
- Mark a perimeter box 6" away from the rough opening sill, jambs and head.
- Cut the DuPont™ Tyvek® WRB along perimeter marking to expose window and DuPont™ Tyvek® WRB frame below. Do not cut DuPont™ Tyvek® WRB frame underneath.
- Create 6" horizontal slits in the DuPont™ Tyvek® WRB at each lower corner of the perimeter cut.
- Bring the bottom portion of the DuPont™ Tyvek® WRB frame through the slits so it laps over the top layer of DuPont™ Tyvek® WRB.
- Tape seams at bottom, sides, and top of rough opening using DuPont™ Tyvek® Tape.

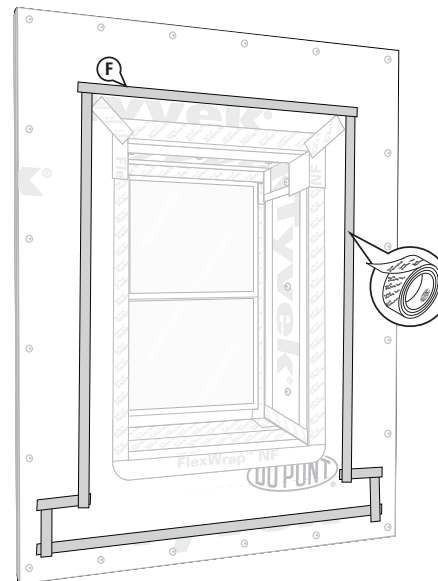
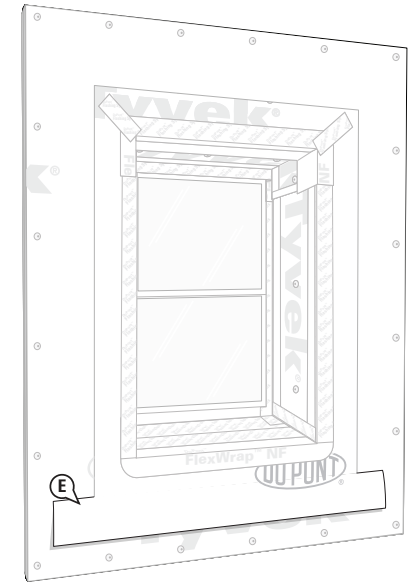
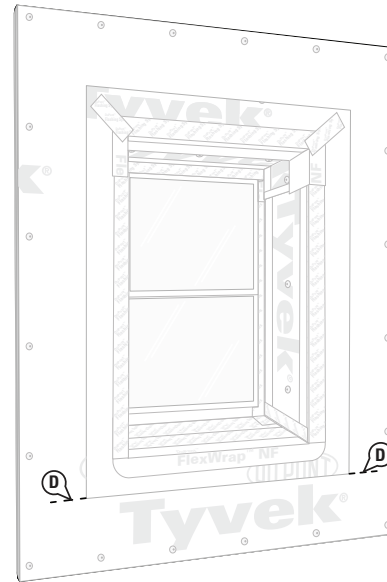
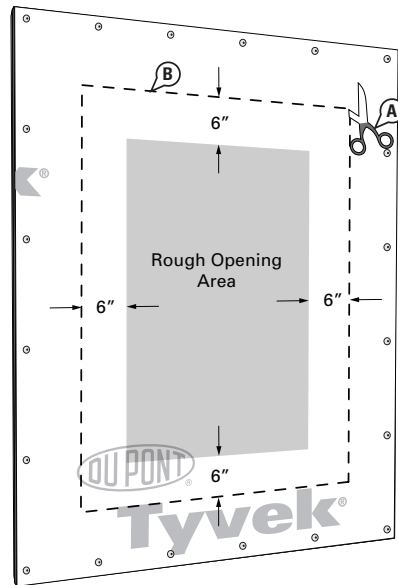
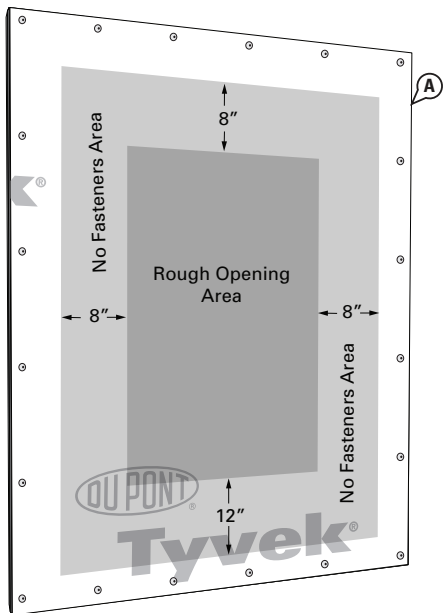

Installation of Integral Flanged Windows in Recessed Openings Greater than 4" Before Water-Resistive Barrier (WRB) Is Installed

Corner Release Paper Removal Guide for ALTERNATIVE METHOD described on page 7

Use the following guide to create a template to aid in removal of the release paper from the corner section only. This will assist in creating the 90° fold between the two release papers.

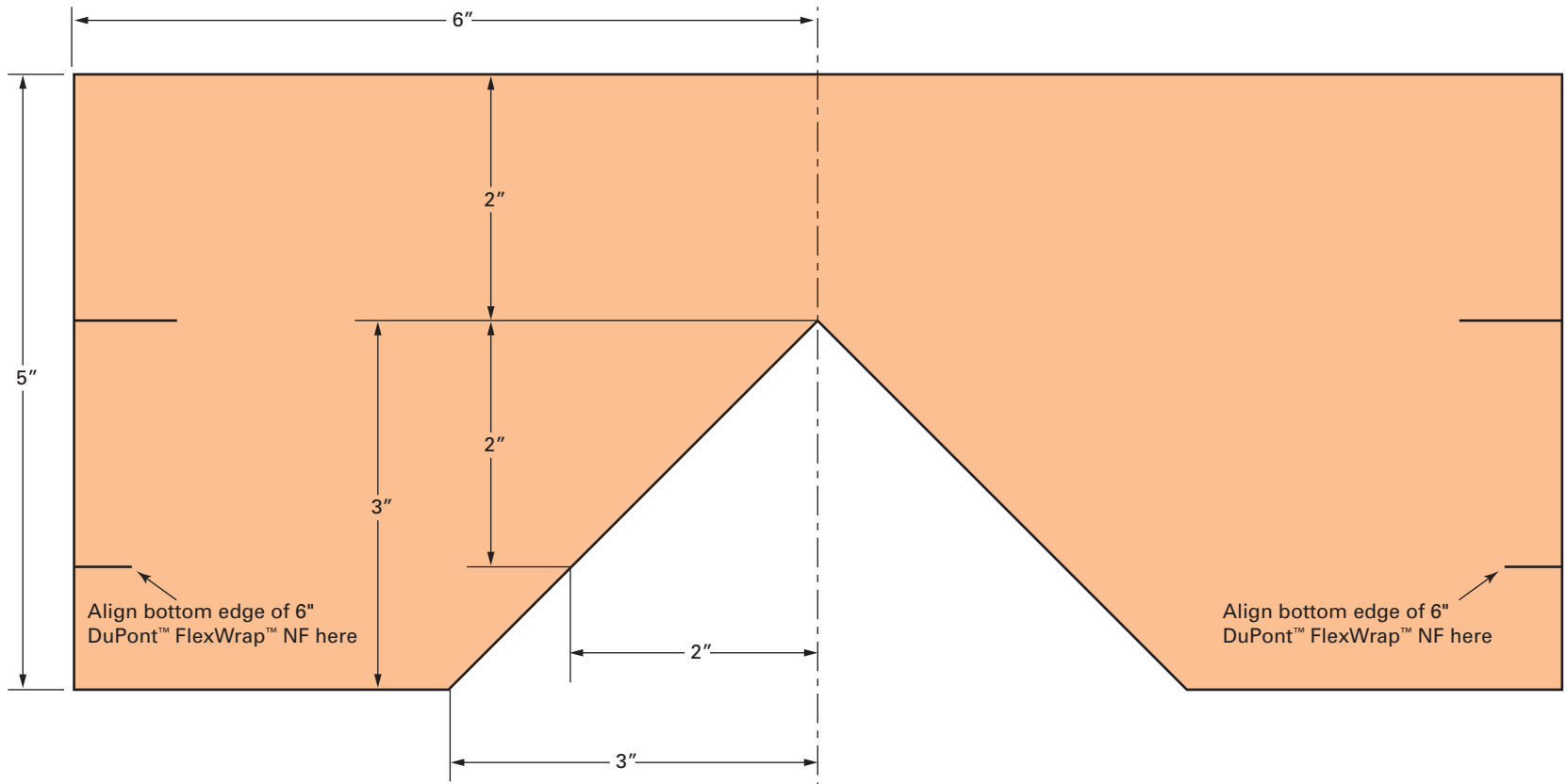

Align the bottom edge of 6" DuPont™ FlexWrap™ NF with the 2" marks (for up to 2" recess). Align the bottom edge of 9" FlexWrap™ NF with the lower edge of the template (for recesses greater than 2").

For best results, create a reusable template using a piece of heavy/rigid plastic. The template can also be used as a guide when tearing the release paper. Otherwise, use the template to mark the release paper and then use a metal straight edge to assist in tearing the release paper. **Do not cut the release paper with a knife or other sharp object** as this could result in damage to the butyl and compromise protection provided by the FlexWrap™ NF Recessed Window Corners.

Technical Specifications

DuPont™ Tyvek® WRBs used in construction products are made from 100% flash spunbonded high density polyethylene fibers which have been bonded together by heat and pressure, without binders or fillers, into a tough durable sheet structure. Additives have been incorporated into the polyethylene to provide ultraviolet light resistance. DuPont requires that DuPont™ Tyvek® CommercialWrap® and CommercialWrap® D be covered within nine months (270 days) of installation and that all other DuPont™ Tyvek® WRB's be covered within 4 months (120 days) of installation.

DuPont™ self-adhered flashing products are made from a synthetic rubber adhesive and a laminate of polyethylene film, polypropelene film, elastic fiber, synthetic rubber adhesive, polyurethane adhesive, and a top sheet of flash spunbonded high density polyethylene fibers or polypropelene film. Additives have been incorporated into these materials to provide ultraviolet light resistance. DuPont requires that DuPont™ FlexWrap™ NF, and StraightFlash™ be covered within nine months (270 days) of installation. DuPont requires that DuPont™ Flashing Tape be covered within four months (120 days) of installation.

Warning

DuPont™ Tyvek® WRBs are slippery and should not be used in any application where they will be walked on. In addition, because they are slippery, DuPont recommends using kickjacks, scaffolding, or lifts for exterior work above the first floor. If ladders must be used, extra caution must be taken to use them safely by following the requirements set forth in ANSI Standards 14.1, 14.2, and 14.5 for ladders made of wood, aluminum, and fiberglass, respectively. DuPont™ Tyvek® products are combustible and should be protected from flames and other high heat sources. DuPont™ Tyvek® products will melt at 275°F (135°C) and if the temperature of DuPont™ Tyvek® reaches 750°F (400°C), it will burn and the fire may spread and fall away from the point of ignition. For more information, call 1-800-44-Tyvek.

DuPont™ self-adhered flashing products and their release paper are slippery and should not be walked on. Remove release paper from work area immediately. DuPont™ self-adhered flashing products will melt at temperatures greater than 250°F (121°C). DuPont™ self-adhered flashing products are combustible and should be protected from flames and other high heat sources. DuPont™ self-adhered flashing products will not support combustion if the heat source is removed. However, if burning occurs, ignited droplets may fall away from the point of ignition. For more information, call 1-800-44-Tyvek.

DuPont™ Residential Sealant is irritating to skin, eyes, and respiratory tract. For proper usage, follow directions stated on the product label. For health information, refer to the Material Safety Data Sheet or call Chemtrec at 1-800-424-9300.

For more information about DuPont Weatherization Systems, please call 1-800-44-Tyvek or visit us at www.weatherization.tyvek.com

Note

When installed in conjunction with other building materials, DuPont™ self-adhered flashing products must be properly shingled with these materials such that water is diverted to the exterior of the wall system. DuPont™ Tyvek® products are air and water barriers and not the primary water barrier. The outer facade is the primary barrier. You must follow facade manufacturer's installation and maintenance requirements for all facade systems in order to maintain water holdout properties and ensure performance of DuPont™ Tyvek® WRBs. Use of additives, coatings or cleansers on or in the facade system may impact the performance of DuPont™ Tyvek® WRBs. DuPont™ Tyvek® Weatherization Systems products are to be used as outlined in this installation guideline. DuPont™ self-adhered flashing products should only be used to seal penetrations and flash openings in houses or buildings. DuPont™ self-adhered flashing products are not to be used in roofing applications. For superior protection against bulk water penetration, DuPont suggests a system combining a quality exterior facade, a good secondary air and water barrier and exterior sheathing, high quality windows and doors, and appropriate flashing materials paying attention to proper installation of each component. In a system where no exterior sheathing is used and DuPont™ Tyvek® WRBs are installed directly over the wall studs, exterior facade materials should be selected to ensure maximum protection against water intrusion. Careful workmanship and proper installation of each component is very important.

DuPont believes this information to be reliable and accurate. The information may be subject to revision as additional experience and knowledge is gained. It is the user's responsibility to determine the proper construction materials needed.

For complete warranty information please visit www.weatherization.tyvek.com or call 1-800-44-Tyvek.

This information is not intended to be used by others for advertising, promotion, or other publication for commercial purposes.



Tyvek®