

Layout Parts

- (1) Table top
- (2) Leg assembly
- (1) Short brace
- (2) Long brace
- (2) Angle brace

Model: PT3672

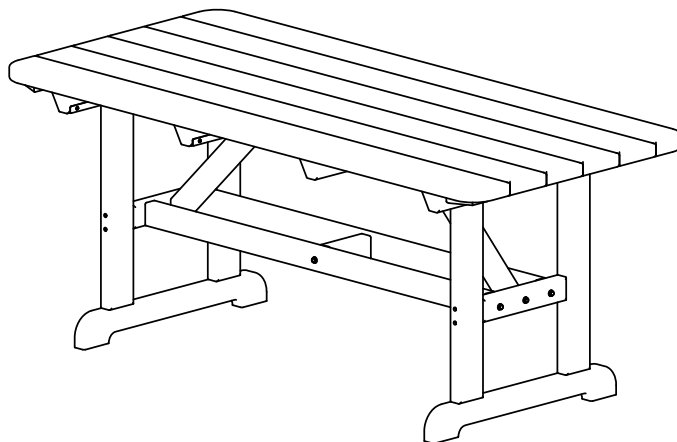

Layout Hardware

QTY

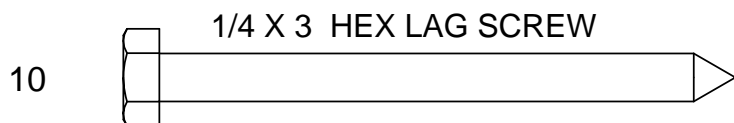
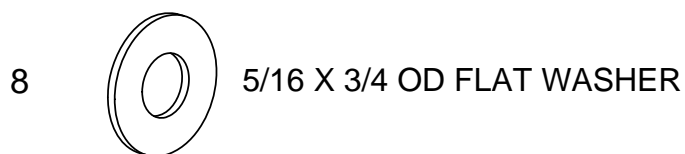
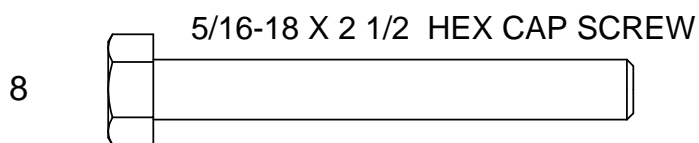

Tools Needed

1/2" Socket drive
7/16 Socket drive

Assembly steps

Assembly Instructions Model: PT3672

1

- Place table top face down on clean, smooth surface
- Attach legs to top using (8) 5/16x2-1/2" Lags and Washers

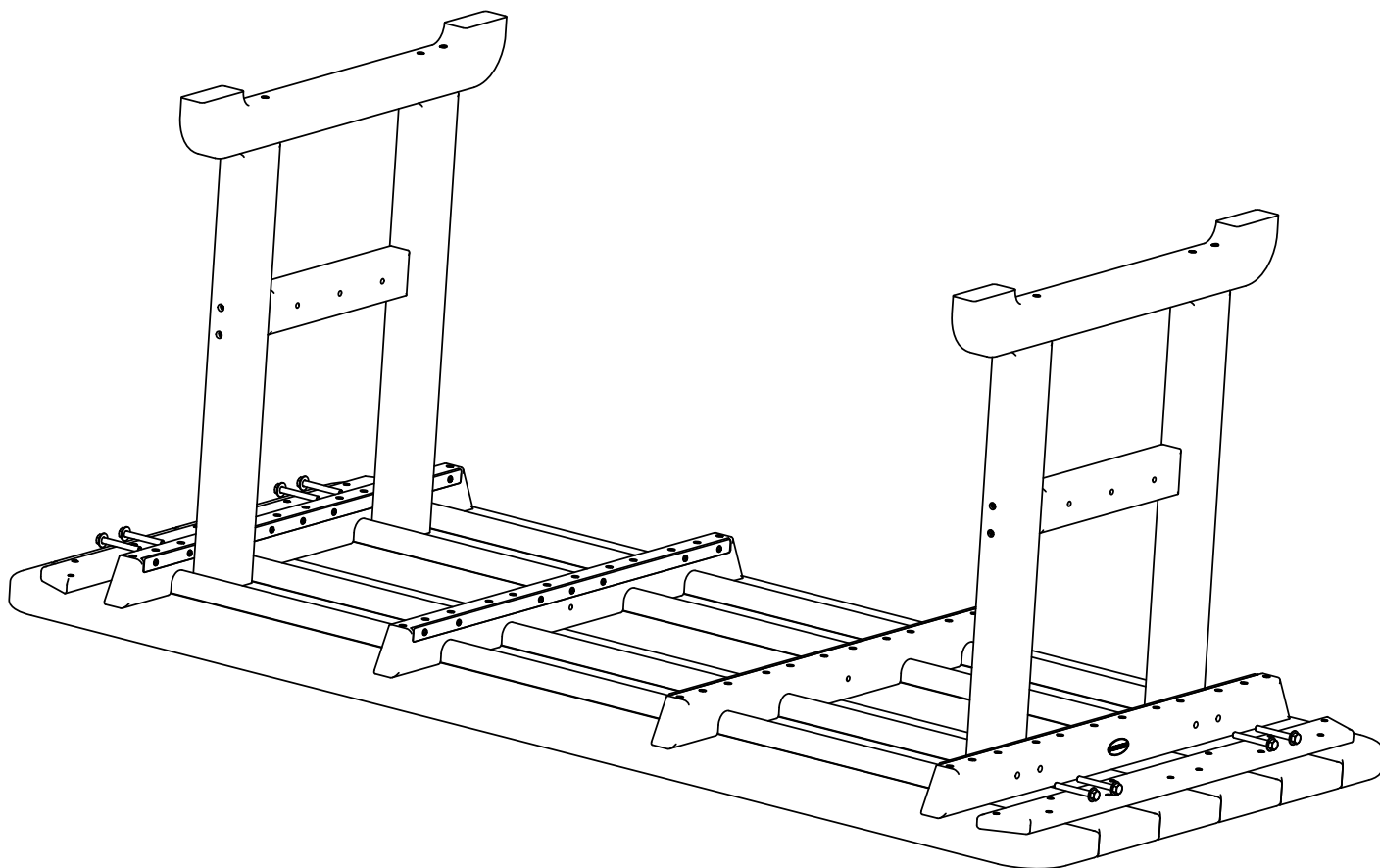

2

- Attach long braces to legs using
(4) 1/4x3" Lags and Washers

- Attach short brace to long brace using
(2) 1/4x3" Lags and Washers

Assembly Instructions Model: PT3672

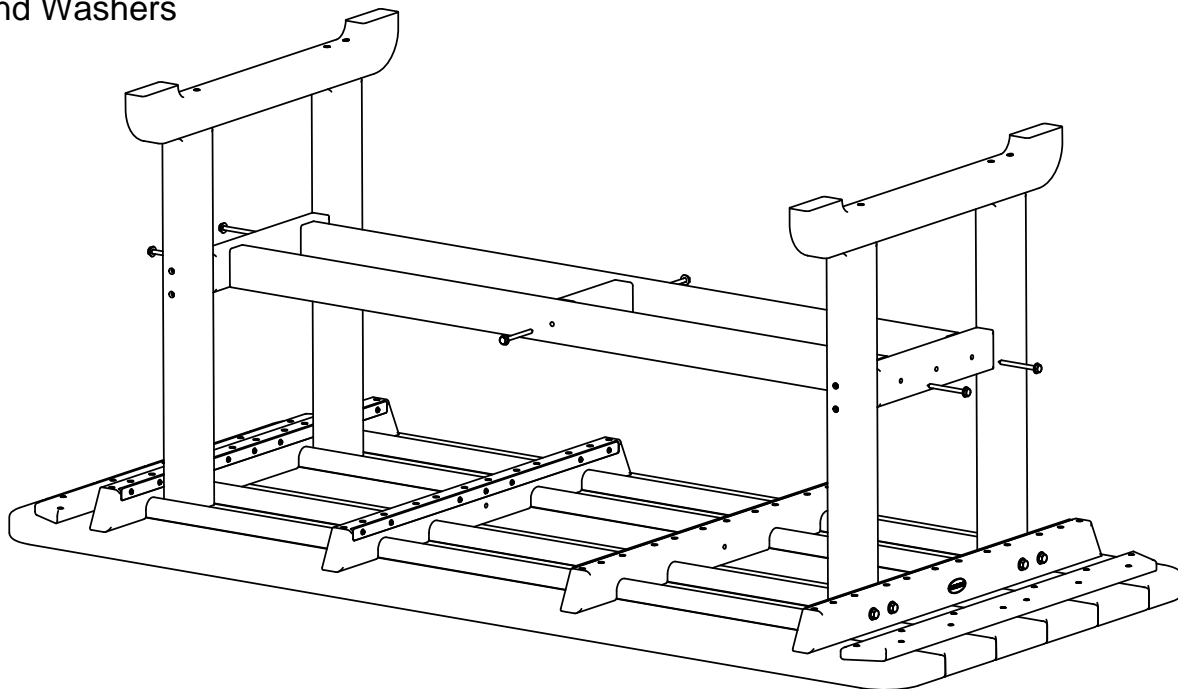
**3**

-Attach angle braces to legs using
(2) 1/4x3" Lags and Washers

-Attach angle braces to top using
(2) 1/4x3" Lags and Washers

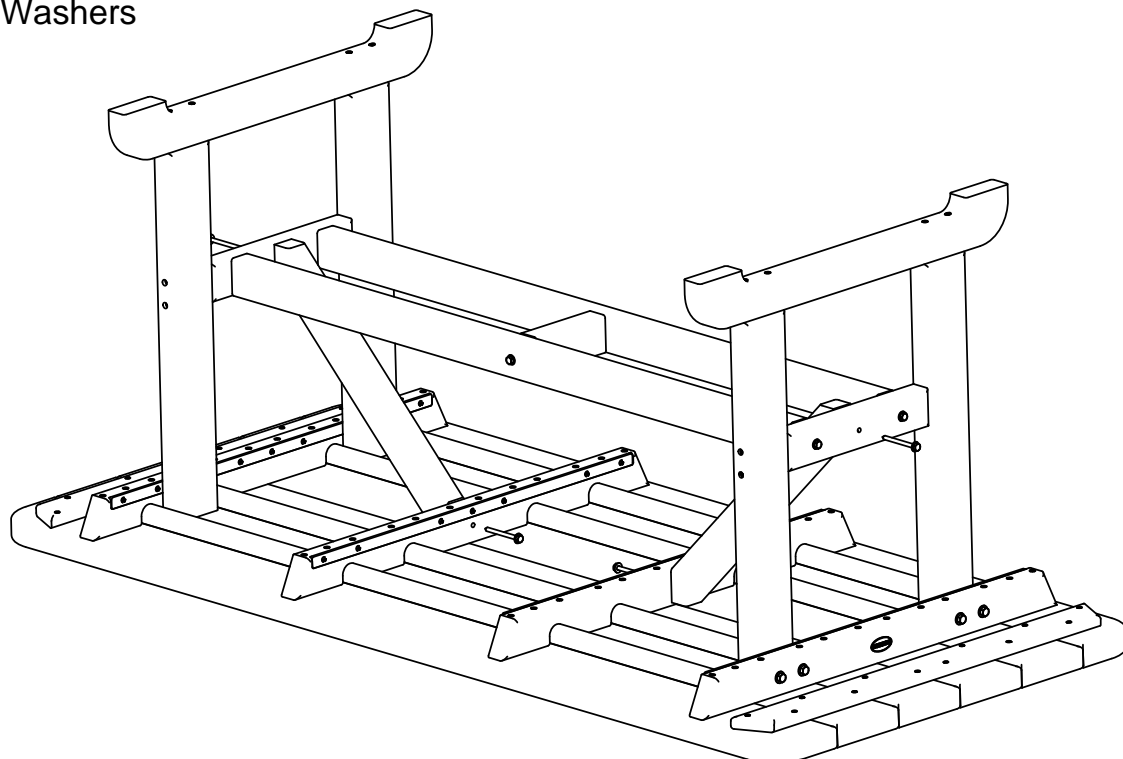

POLYWOOD®

All Weather Furnishings

Join the POLYWOOD® Community
Share in the love of outdoor living, recycling, and more...



POLYWOOD



@POLYWOODINC



youtube.com/polywood



POLY-WORLD
Blog



POLYWOOD



To view our full warranty, please visit the warranty page on our website at polywoodinc.com/resources.

If you have questions or concerns regarding assembly instructions or missing parts, please contact us at (877) 457-3284 or email support@polywoodinc.com