



# TidalWave

MAG DRIVE SERIES

## Operating Manual

Includes Pumps:

MD250  
MD350  
MD550  
MD750  
MD1000  
MD1250  
MD1500  
MD2000

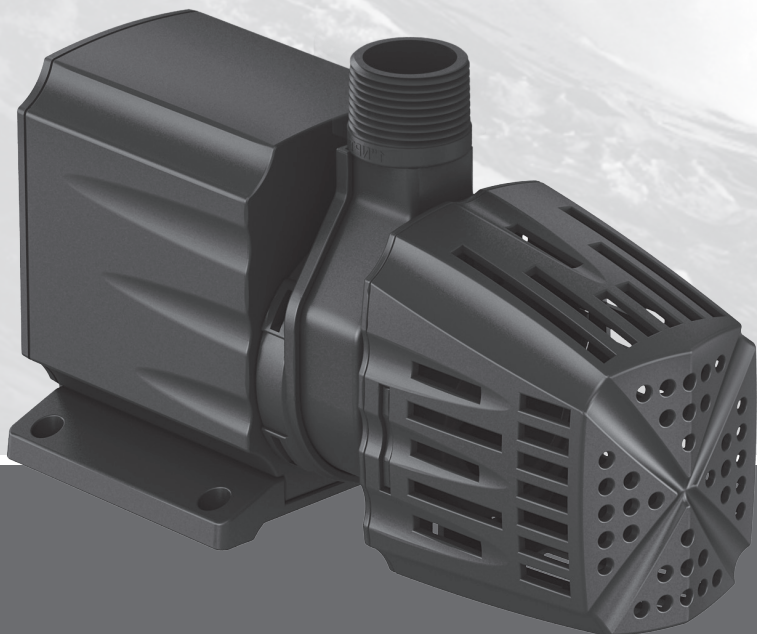

1-877-80-PONDS  
[www.atlanticwatergardens.com](http://www.atlanticwatergardens.com)

## Introduction

Thank you for selecting the TidalWave MD250, MD350, MD550, MD750, MD1000, MD1250, MD1500 or MD2000 series pump. Before using this pump please take a moment to review this manual.

To avoid an accident do not use the pump in any way other than as described in this manual. Please note the manufacturer cannot be responsible for accidents arising because the product was not used as prescribed. After reading this manual keep it as a reference in case questions arise during use.

### Flow Chart: (GPH)

Model #	Watts	Max	5'	10'	15'	20'
MD250	15	300				
MD350	25	370	145			
MD550	40	650	385			
MD750	50	790	465			
MD1000	90	1080	785	275		
MD1250	120	1330	1040	580		
MD1500	165	1560	1255	780		
MD2000	250	2010	1695	1320	695	

MD1000, MD1250, MD1500 and MD2000 pumps include an 1½" adaptor for use with the Triton Check Valve and Atlantic Plumbing Kits. This adaptor makes the discharge height of the Mag Drive Series pumps equal to the TW2400 pump. If using a Mag Drive Series pump with the Triton Check Valve, Colorfalls Kit or Fountain Basin Plumbing kits, please reference the plumbing instructions for a TW2400 as outlined in the installation manuals for these items.

## Prior to Operation and Installation

- When the pump is delivered, first perform the following checks:
  - Check for any damage to pump and power cable that may have occurred during the shipment.
  - Check the model number to make sure it is the product that was ordered and verify the voltage and frequency are correct.

## Caution

- DO NOT operate this product under any condition other than those for which it is specified. Failure to observe this precaution can lead to electrical shock, electrical leakage, fire, water leakage or other problems.
- The pump is a 110/120 volt 60 Hz pump, please only use with a power supply voltage within 110-120 volt 60 Hz.
- Never place your hand or any object in or near the inlet opening while this equipment is operating. If pump inlet is clogged, always turn off the power supply and wait until the motor is completely stopped before attempting to remove any clogged material.
- Please make sure that the power plug and the AC outlet receptacle are protected and away from water or pump discharge hose to prevent accidental electric shock or short circuit.
- Always operate the pump completely submerged in water.
- Avoid dry operation, which will not only lower performance but can cause the pump to overheat/malfunction, leading to electrical leakage, shock or premature failure.
- Always turn off power or unplug the pump prior to performing any maintenance or placing your hands into the water.

- **CAUTION:**  
THIS PUMP IS TO BE USED IN A CIRCUIT PROTECTED BY A GROUND CIRCUIT INTERRUPTER.
- **CAUTION:**  
THIS PUMP HAS BEEN EVALUATED FOR USE IN WATER ONLY.
- **WARNING:**  
RISK OF ELECTRIC SHOCK - THIS PUMP IS SUPPLIED WITH A GROUNDING CONDUCTOR AND GROUNDING-TYPE ATTACHMENT PLUG. TO REDUCE THE RISK OF ELECTRIC SHOCK, BE CERTAIN THAT IT IS CONNECTED ONLY TO A PROPERLY GROUNDED, GROUNDING TYPE RECEPTACLE.

## Electrical Safety

- Electrical wiring should be installed by a qualified electrician in accordance with all applicable safety regulations. Incorrect wiring can lead to a pump malfunction, electrical shock or fire.
- Pumps should operate on a designated, 110/120 volt circuit.
- Pump must be protected by a ground fault circuit interrupter (GFCI).
- Pump must be plugged into a standard, properly grounded, three pronged outlet.

## Safety Instructions



Make sure the pump works at a proper water level. Do not operate the pump without water. If so, the pump should be turned off immediately and check.

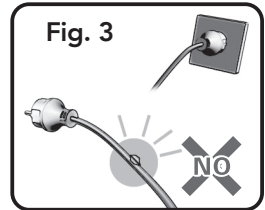
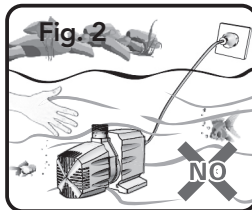
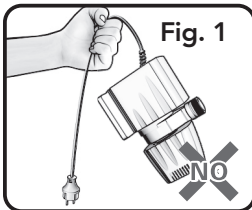

- Do not lift, lower or handle the pump by pulling on the electrical cord. Make sure the electrical cable does not become excessively bent or twisted and does not rub against a structure in a way that might damage it. (Fig. 1)
- Always disconnect the power supply before doing any maintenance or placing your hands into the water to which this pump is immersed. (Fig. 2)
- The submersible pump should not be used if the electrical supply cable is damaged in any way. If a cable with damaged insulation is submerged in water, there is danger of water seeping into the pump motor and causing a short. The electrical cable cannot be replaced. If the cord is damaged, the pump should be discarded. Altering the electrical cable in any way will void the warranty. (Fig. 3)

## Operation

- Mag Drive Series pumps are for use in water only. Water temperature should never exceed 95° F (35° C).

- Mag Drive Series pumps must not be used to pump salt water, sewage, flammable or corrosive liquids, greases, oils or food waste.
- Pay careful attention to the water level while the pump is operating. The pump must be fully submersed at all times of operation.
- Repeating cycles of stopping and restarting will damage the water pump. Do not continue operation at low water level or while the inlet is clogged with debris. Not only will performance suffer, but also such conditions may cause noise, heavy vibration, and pump failure.
- In case of excessive vibration, unusual noise or odor, turn off the power immediately and consult your nearest dealer.

## Maintenance and Inspection

- Regular maintenance and inspections are a necessity for continued efficient functioning. If any abnormal conditions are noticed, refer to the section on Troubleshooting and take corrective measures immediately.

### Monthly Inspection

- Check for any drop in performance. Reduced performance is usually caused by debris blocking the pump intake.
- Detach the power cable from the receptacle or turn off the power supply (circuit breaker).
- Disconnect the pump discharge and remove the pump from the water.
- Remove any accumulated debris from the surface of the pump and pre-filter.
- Unthread the pre-filter by turning it in a counter clockwise direction. Inspect the threaded inlet on the volute and remove any accumulated debris.
- Remove volute by rotating it in a counterclockwise half turn while pulling lightly outward from the pump body.
- Inspect the impeller. The impeller should spin freely. If the impeller feels tight or gritty when spun, please refer to the cleaning instructions on page 5.

### Winterizing

- Under no circumstances should the pump be left in frozen water.
- When the pump is out of use for an extended period, wash it and dry it thoroughly, then store it indoors.

**Note:** Always run a test operation before putting the pump back into operation. When the pump is left installed in water it should be run at regular intervals (about once per week).

### Warranty

All TidalWave Mag Drive Series Pumps carry a three-year limited warranty. This limited warranty is extended solely to the original purchaser commencing from the date of original purchase receipt and is void if any of the following apply:

- The pump has been run while not fully submersed.
- The pump was not run on a dedicated circuit.
- The cord has been cut or altered.
- The pump has been misused or abused.
- Pump has been disassembled other than as described in this manual.
- Serial number tag has been removed.

## Warranty Claims

- In case of warranty claims, pump should be returned to place of purchase accompanied by original receipt.

## Cleaning

Mag Drive pumps will require periodic cleaning of the magnetic rotor and rotor chamber. Please follow the directions below for proper cleaning procedures:

- Unthread the pre-filter by turning it in a counter clockwise direction.
- Remove volute by rotating it in a counterclockwise half turn while pulling lightly outward from the pump body.
- Remove the impeller assembly from the rotor chamber.

**Note:** The impeller assembly is comprised of six individual parts shown in the image below. Take care not to lose or misplace any of these pieces during the cleaning process.

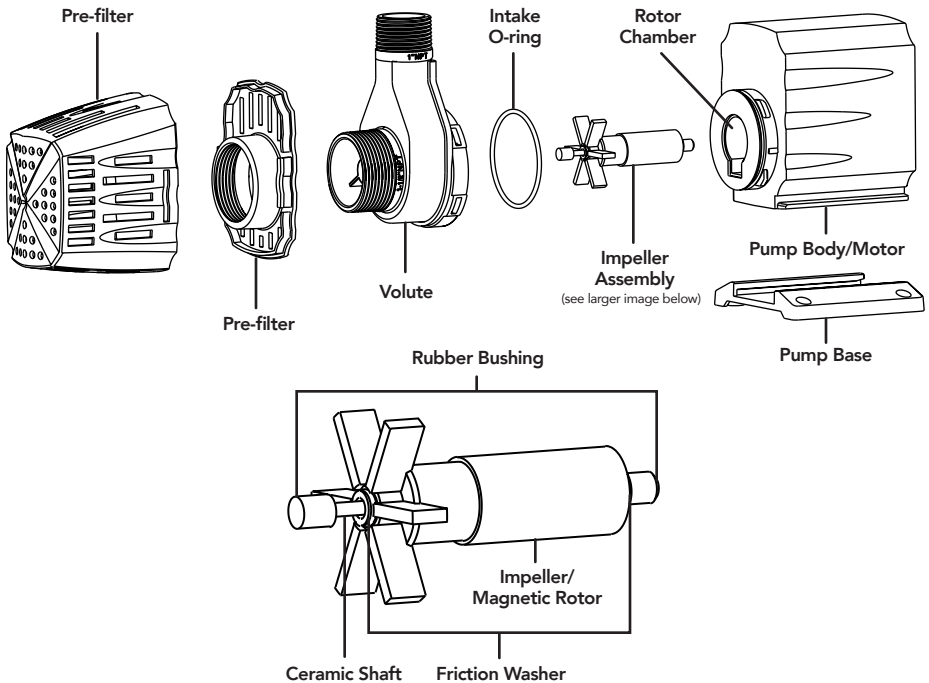

- Inspect the magnetic rotor and the rotor chamber for built up debris. Loose debris can be flushed out with clean water. Often in hard water, well water or pond-free applications, debris may appear as a crusty film around the rotor and in the rotor chamber. Remove this film using a scrub brush and white vinegar.
- Inspect the intake O-ring for nicks or breaks.
- Re-assemble the impeller assembly insert it into the rotor chamber.
- Attach the volute by applying pressure and rotating it in a clockwise half turn.
- Replace the pre-filter.

## Troubleshooting Guide

Always turn off power before inspecting the pump. Failure to observe this precaution can result in a serious accident.

Before ordering repairs, carefully read through this instruction booklet. If the problem persists, contact your dealer.

Problem	Possible Cause	Possible Solution
Pump does not run	Power is off	Turn power on
	Power failure	Check power supply or contact local power company
	Power cord is not connected	Connect power cord
	Impeller is stuck	Remove debris/clean impeller
Pump stops after starting	Pump is overheating	Submerge pump/Raise water level/ Allow pump to cool/Clean impeller
	Power/Current overload	Check length/size of power cable. Check or replace GFI
	Intake is blocked/ Impeller needs cleaned	Remove debris from the pump intake. Refer to page 5 for cleaning instructions.
Diminished flow rate or no water flow	Impeller needs cleaned	Refer to page 5 for cleaning instructions
	Obstruction in pump or piping	Clear obstruction
	Low water level	Stop operation/Raise water level
	Air-lock in the impeller chamber	Place pump in water. Turn the pump ON/OFF intermittently 2 or 3 times.



1-877-80-PONDS

[www.atlanticwatergardens.com](http://www.atlanticwatergardens.com)