

BUILD↑TUFF

Smarter Building Systems

DISCOVER SMARTER

Step by step Installation guide

25 YEAR WARRANTY

Stronger than concrete blocks!

Designed to support 1,700 lbs & tested to over 11,000 lbs

Accepts 4" x 4" posts & 2" joists

28 times lighter than concrete blocks at just 1½ lbs each

Using the world's most trusted floating foundation system for over 35 years

Low profile design



100% RECYCLED

Proudly made in both the USA and Australia



Water Channels prevent moisture build up



Deters Termites, Ants, Silverfish & other pests



Long Lasting UV Stabilised Polyolefin



100% Recycled and Recyclable



Each TuffBlock can support 1,700lbs



Each TuffBlock weighs only 1.5lbs

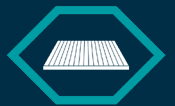

Build decks as low as 6"



Accepts 2" Joists & Bearers



Accepts 4" x 4" Posts

TUFFBLOCK

No digging holes.
No mixing concrete.
No trips to the chiro.
Build on.

TUTORIALS
REVIEWS
& HOW TOS

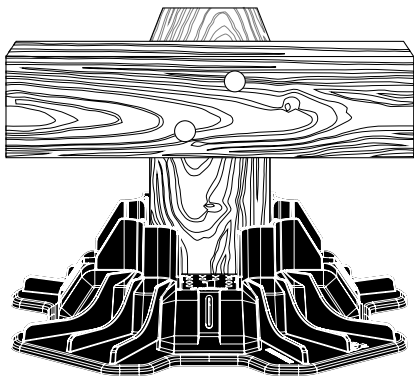
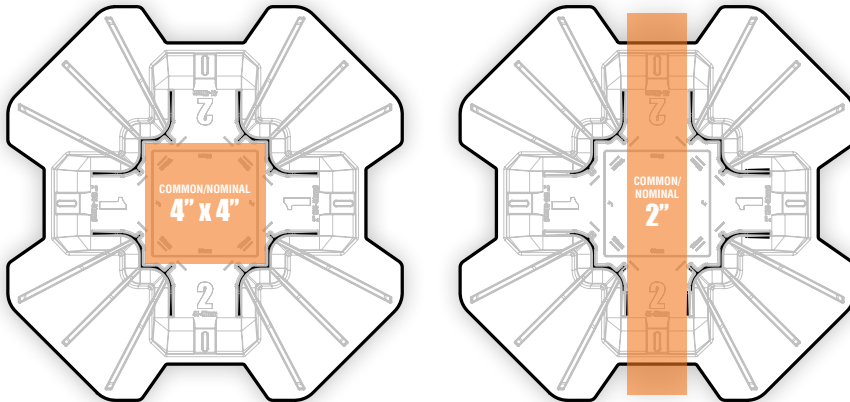
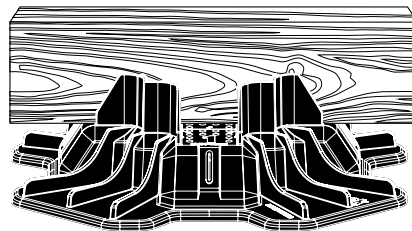

BUILDTUFF.COM

DIMENSIONS Standard Configuration - Imperial**RAISED INSTALLATION****LOW PROFILE INSTALLATION****HEIGHT RESTRICTIONS**

TuffBlocks are not designed for use in structures elevated more than 48" from the ground and should be installed on stable ground (see www.buildtuff.com for more details). As always, it is recommended to check your local building guidelines before starting any construction - we always suggest you get approval before starting your project.

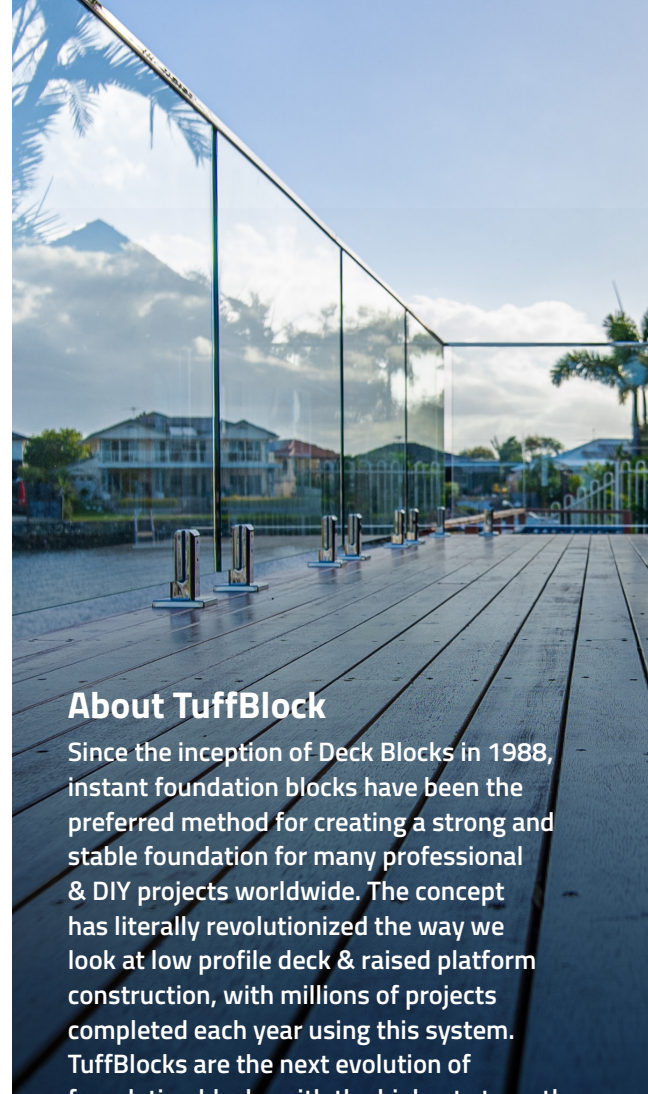
**About TuffBlock**

Since the inception of Deck Blocks in 1988, instant foundation blocks have been the preferred method for creating a strong and stable foundation for many professional & DIY projects worldwide. The concept has literally revolutionized the way we look at low profile deck & raised platform construction, with millions of projects completed each year using this system. TuffBlocks are the next evolution of foundation blocks with the highest strength to weight ratio of any block on the market.

TuffBlock's are made of high strength closed loop recycled polyolefin material with an ultra high UV rating. Designed with a ventilated underside to prevent moisture buildup and deter wood ingesting insects. TuffBlock's are even able to be secured to the post/bearer for extra stability.

An individual TuffBlock can support over 1,700 lbs and weighs only 1½ lbs. Designed to accept 2" x 4", 2" x 6", and 2" x 8" Joists and 4" x 4" Posts, TuffBlocks truly are the lightest, most versatile and easiest to use deck foundation system on the market.

Unique to the TuffBlock is the ability for low level decking, it is now possible to build a deck as low as 6½ inches without the need for digging. No more ugly concrete blocks in your yard. The slimline profile and satin black finish means a TuffBlock easily blends into the landscape and surrounds.

TuffBlocks are more than just a deck foundation, they are a versatile utility block that can be used for a large number of applications.

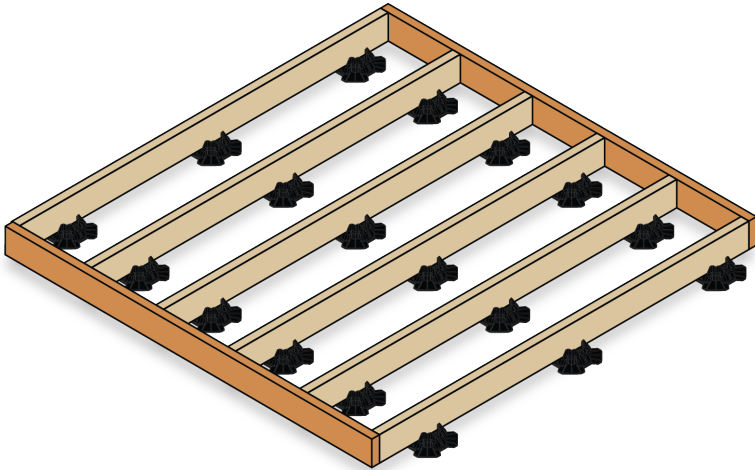

Raised decks»

TuffBlock's allow for use with $3\frac{1}{2}'' \times 3\frac{1}{2}''$ - $4'' \times 4''$ Posts, allowing your deck to be elevated to any height desired.*

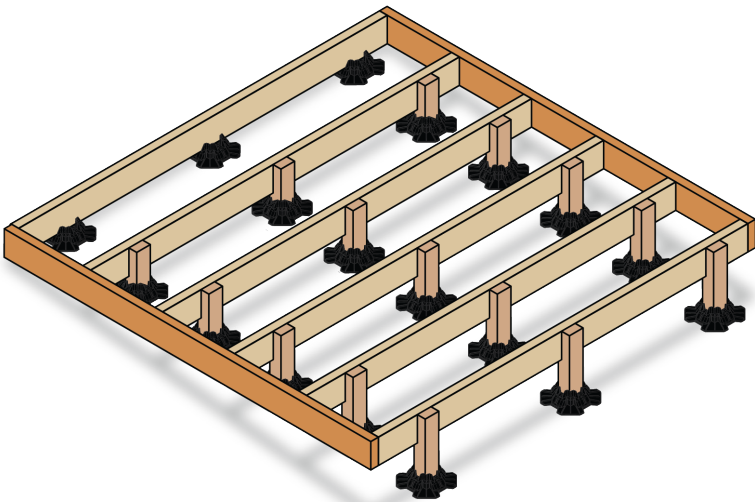

Intermediate footing decks»

Should you wish to lock down your project, it is possible to use TuffBlock's in combination with the traditional concrete and steel post support method (TuffBlocks become an intermediate support). This is an excellent option for those looking to build in high wind load areas, or build decks higher than 48". As always, consult with your local engineers and code prior to construction.

«Ultra-low profile decks

TuffBlock's extremely low profile design means decks as low as 6 inches are now a possibility as previously floating foundation systems have always been flawed when it comes to low profile decking.

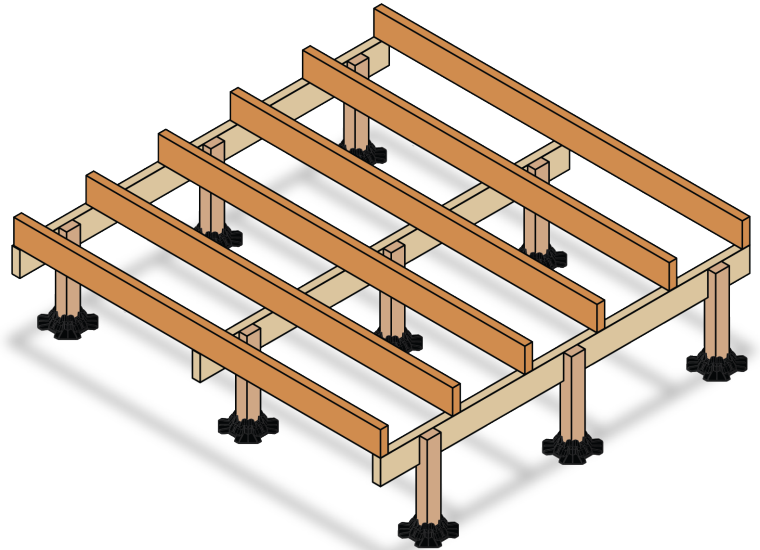

«Variable height decks

Got a sloping or uneven surface? Due to TuffBlock's incredible adaptability variable height decks are a breeze to install.

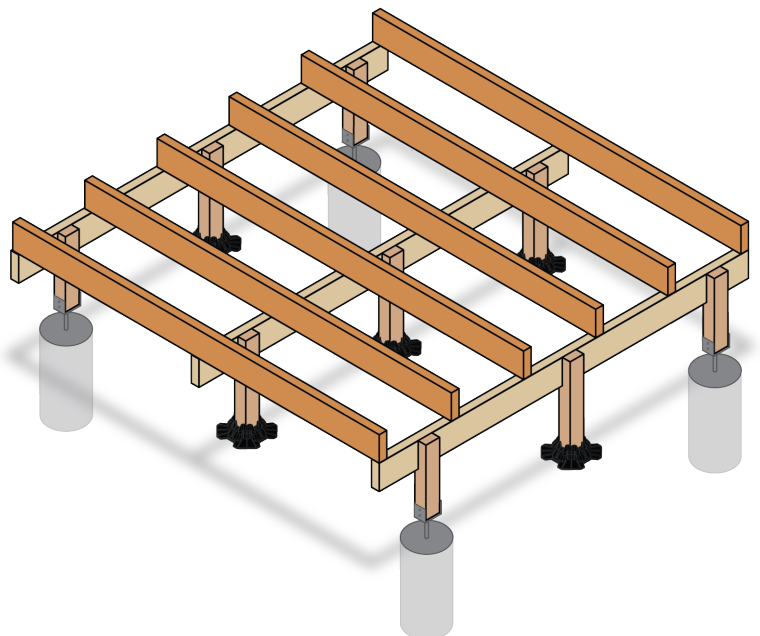

* TuffBlocks are not designed for use in structures elevated more than 48" from the ground and should be installed on stable ground (see www.buildtuff.com for more details). As always, it is recommended to check your local building guidelines before starting any construction - we always suggest you get approval before starting your project.

TuffBlock floating foundation engineering specifications

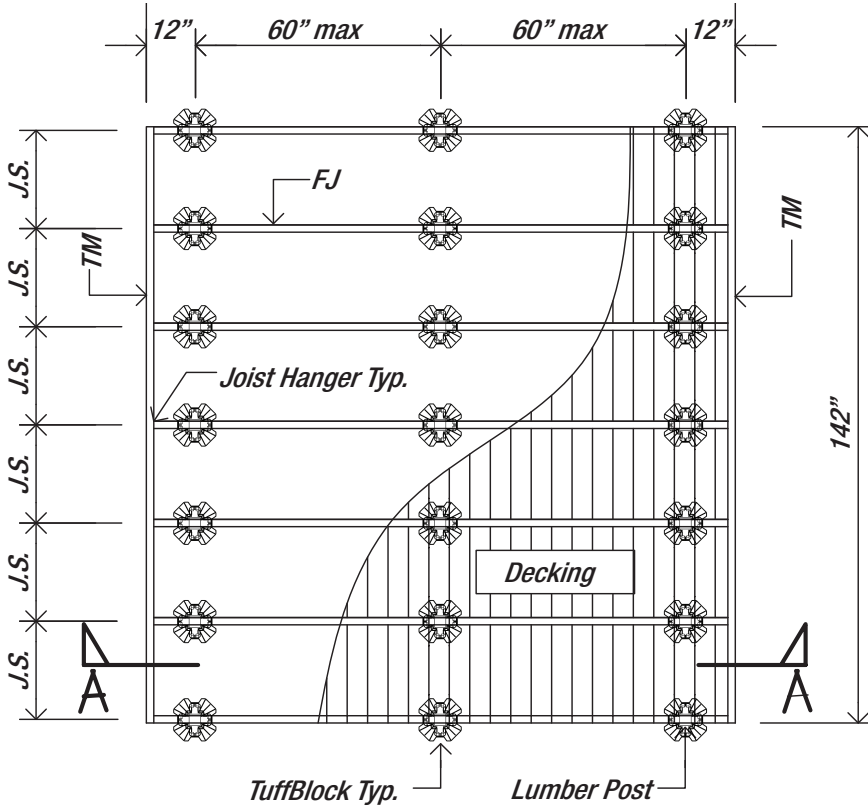

Section A-A

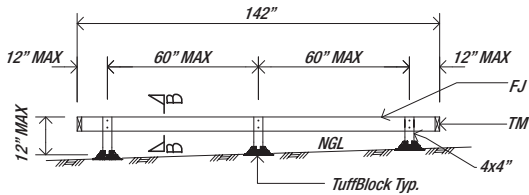

Section B-B

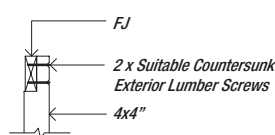

OPTION 1 - Example

J.S. Joist Spacing = 16" (Centers)

Decking 3 1/2" x 1"

FJ 4 3/4" x 2" Floor Joists @ 16" CRS (Continuous)

TM 4 3/4" x 2" Trimboard

Post 4" x 4"

The above is an example only. Actual spacing of other structural materials such as lumber, composite, steel and pressure treated will depend on the manufacturers specifications. Please refer to these specifications when building your design.

The general rule of thumb is to space joists at 16" centers (maximum). This spacing depends on your decking or platform material so check with your lumber supplier for project specific recommendations. Joists can sit directly on TuffBlocks (e.g. TuffBlock - joists - decking/platform) or on top of a substructure (e.g. TuffBlock - bearers - joists - decking/platform).

Glossary

J.S. Joist Spacing FJ - Floor Joists

TM Optional Trim Board

Maximum 5' Spacing between TuffBlocks

Set-up for 8", 10" and 12" Support Boards



Set-up for Support Boards End to End

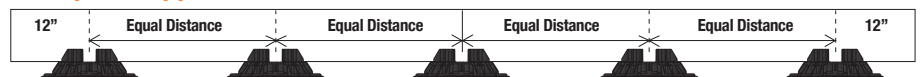

Set-up for raised and uneven platforms

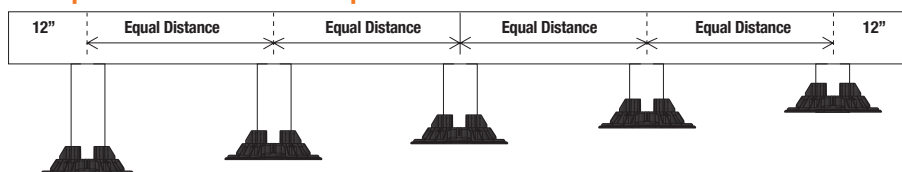

PRECAUTIONS

HOW TO POSITION TUFFBLOCKS ON AN UNEVEN SURFACE

In the event of placing a TuffBlock on uneven surface, please note that in no circumstances are you to 'build up' the footing beneath the TuffBlock. In every instance the underneath footing must be dug out in order for the TuffBlock to be level ground prior to commencing your project. (see images below)

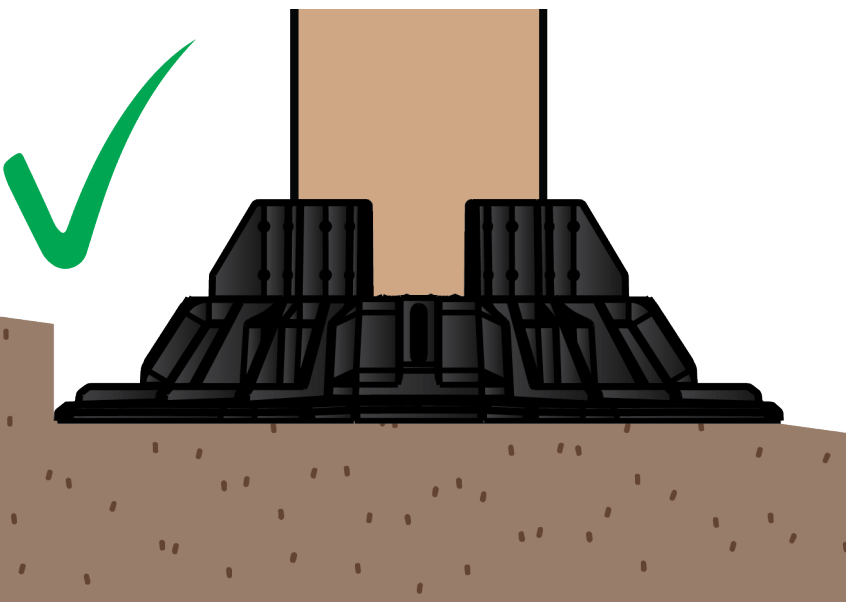
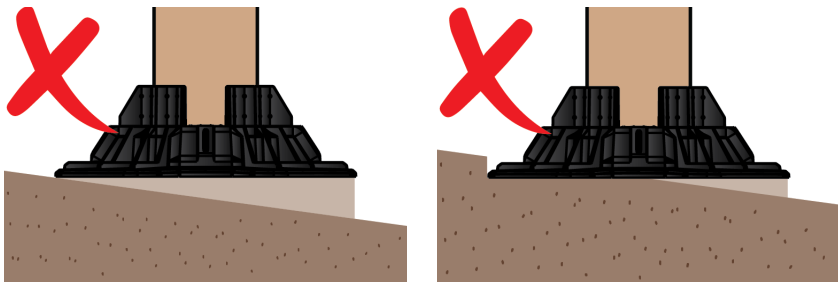

DO NOT MODIFY, CUT, OR MANIPULATE TUFFBLOCKS

By modifying the TuffBlocks in any way shape or form may severely detract from its structural integrity and not be able to perform it's designed task. Failure to adhere to this may lead to damage to property, injury or death.



VOID WARRANTY

Modifying TuffBlock or failing to install correctly will void warranty.



WARANTY
INFORMATION
ONLINE

TUTORIALS
REVIEWS
& HOW TOS



“

« DISCOVER SMARTER »

I found these (TuffBlocks) and watched the video. **It could not have been easier.**

– Eric M / Lowes / July 2020

”

The following illustrations are of an example deck build approximately 10' x 10' on a sloping surface.

STEP 1»»

PLACE THE TWO CORNER TUFFBLOCK PIERS CLOSEST TO AN EXISTING STRUCTURE.

Place the TuffBlocks directly on the ground. If the ground is sloped, remove top soil from directly underneath the block until the block sits level. If the deck is going to be an extension of an existing structure, then the blocks should be as close to the structure as possible. Using the plan on the previous page, ensure the blocks are correctly spaced. The outside edge of the finished deck will extend out past the center of the TuffBlock piers by 14 inches on both sides.

Don't spend an excessive amount of time levelling the TuffBlock piers. The block can be leveled with only your eye. Any slight difference will be made up with the post. However, you want to make sure the TuffBlock piers are sitting FLAT. You do not want any rocking of the piers on the ground.

STEP 2»»

LEVEL THE FLOOR JOIST.

Locate the highest TuffBlock pier. Position a floor joist in or above this first block to your desired height. If the entire deck will be elevated, you will need to have a post in the first TuffBlock.

Place a floor joist in the slot of the TuffBlock pier or on the post and extend over the second corner TuffBlock pier. Now, using a level on top of the floor joist, measure the distance from the top of the floor joist to the bottom of the pocket in the TuffBlock pier. Next cut a post to length allowing for B-B and position the floor joist on top. Make sure to verify that the floor joist is level. Do not attach the floor joist to the post yet.

If the entire deck is to be elevated you will first need to establish the height of the first post, once this is completed continue following the directions above.

STEP 3»»

POSITION AND LEVEL REMAINING CORNER TUFFBLOCK PIERS.

If building off an existing structure, measure from the structure to the outside edge of the post. (For example: If the deck will be 10 feet deep, position the block so that the outside edge of the post is 10 feet from the structure.)

Do NOT use the the first row of blocks as a measuring reference. Use the same width between the TuffBlock piers as the first row.

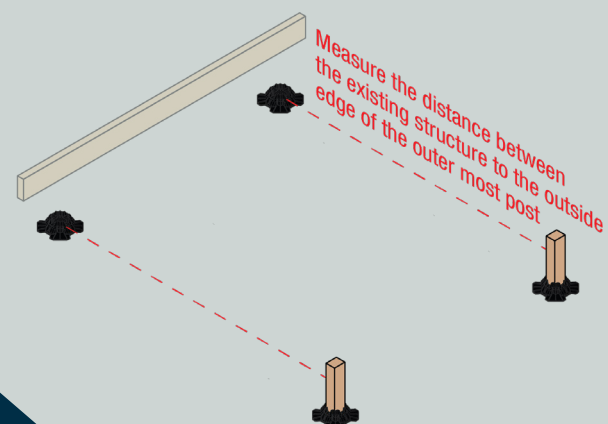
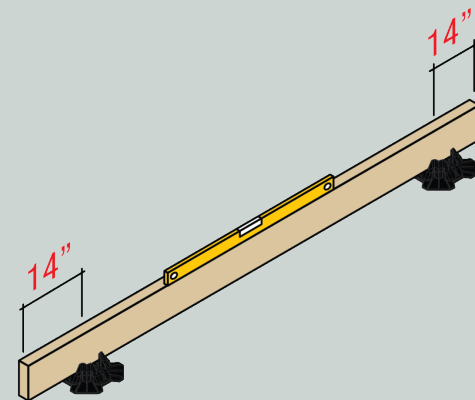
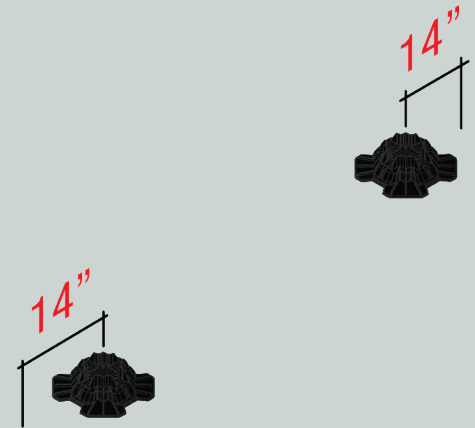

BuildTuff. Build on.

The following illustrations are of an example deck build approximately 10' x 10' on a sloping surface.

STEP 4»

POSITION AND LEVEL REMAINING CORNER TUFFBLOCK PIERS.

Next, remove the first floor joist closest to the structure. Temporarily position a trim board on top of the first row's post or block, and extend it to the outside corner block. Using a level on top of the trim board, measure the distance from the top of the trim board to the bottom of the pocket on the TuffBlock pier. Cut a post to length. Verify the trim board is level. When level, remove the trim board and repeat for opposite the side

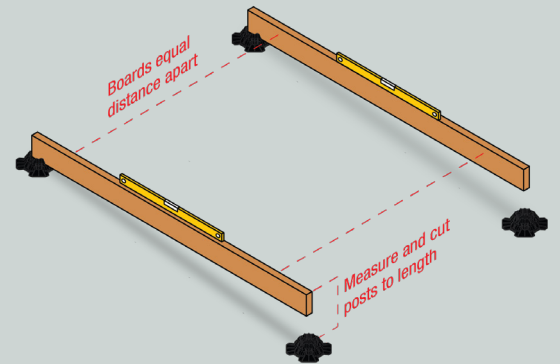

STEP 5»

PLACE THE TWO CORNER TUFFBLOCK PIERS CLOSEST TO AN EXISTING STRUCTURE.

Place the TuffBlocks directly on the ground. If the ground is sloped, remove top soil from directly underneath the block until the block sits level. If the deck is going to be an extension of an existing structure, then the blocks should be as close to the structure as possible. Using the plan on the previous page, ensure the blocks are correctly spaced. The outside edge of the finished deck will extend out past the center of the TuffBlock piers by 14 inches on both sides.

Don't spend an excessive amount of time leveling the TuffBlock piers. The block can be leveled with only your eye. Any slight difference will be made up with the post. However, you want to make sure the TuffBlock piers are sitting FLAT. You do not want any rocking of the piers on the ground.

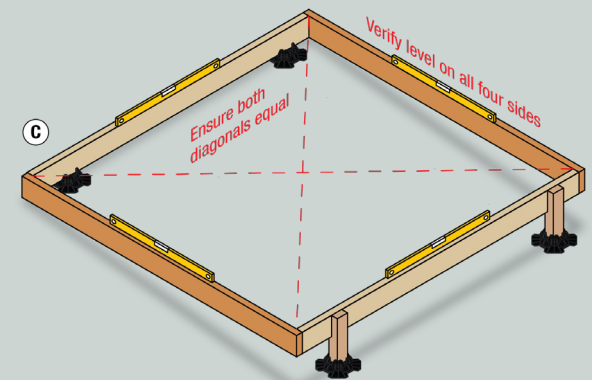
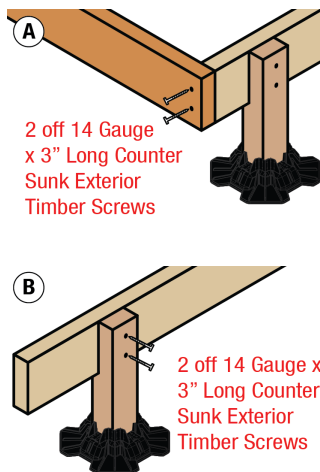

STEP 7»

ATTACH REMAINING FLOOR JOISTS.

Position and attach the remaining floor joists to the trim boards using 3 inch counter sunk exterior lumber screws to attach the floor joist to the trim board.

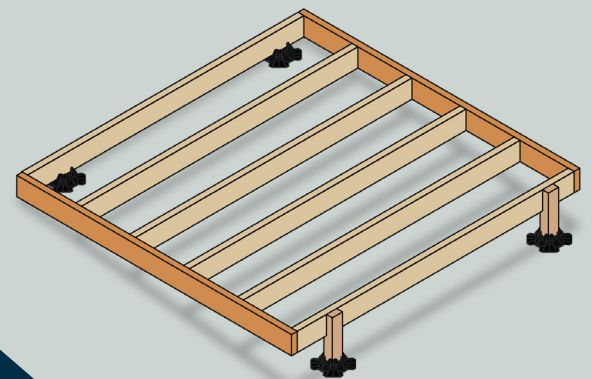

The following illustrations are of an example deck build approximately 10' x 10' on a sloping surface.

STEP 7»»

POSITION REMAINING TUFFBLOCK PIERS.

Using the frame as a guide, position the remaining TuffBlock piers directly beneath the frame. The blocks on the perimeter of the deck should be 12 inches in from each end.

When positioning the blocks, the dimensions do not need to be exact, however, do not exceed the maximum span of 5 feet between blocks, just be sure to have all of the TuffBlock Piers aligned in a straight row and spaced evenly.

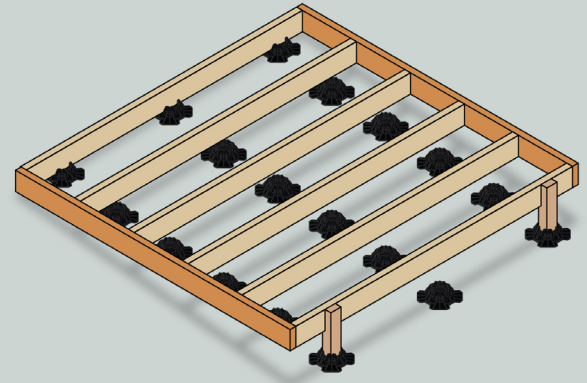

STEP 8»»

FILL THE REMAINING POSTS.

Cut posts to length and position them between the floor joist and the TuffBlock pier. Repeat this step until all posts are cut and positioned. Next, secure all floor joists and posts using 3 inch counter sunk exterior lumber screws.

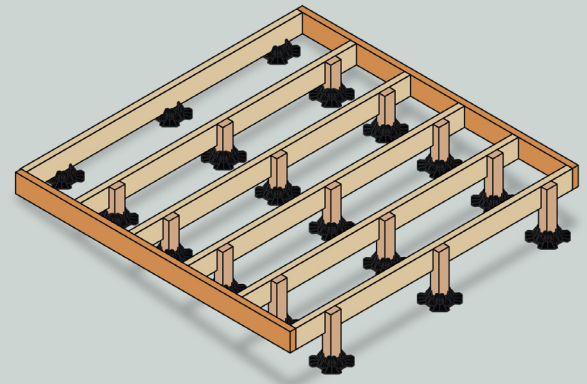

STEP 9»»

ATTACH THE DECKING.

Starting from one side of the deck, attach the first decking board so it's flush to the edge of the deck. The decking board will overhang the first floor joist closest to the existing structure. Leave a 0.125 - 0.25 inch gap between the end of the decking board and the edge of the structure. Next, secure the remaining decking boards as per manufacturers instructions.

