



CERTIFICATION



Approved. Sealed. Code Compliant.

Technical Evaluation Report

TER 1201-01

FastenMaster® HeadLOK® Screws to
Provide Stud to Top & Bottom Plate
Uplift Attachment

**OMG®, Inc.
DBA FastenMaster®**

Product:

**FastenMaster® HeadLOK®
Heavy Duty Wood Screw**

Issue Date:

March 15, 2012

Revision Date:

March 22, 2022

Subject to Renewal:

April 1, 2023



COMPANY
INFORMATION:

OMG®, Inc.
DBA FastenMaster®

153 Bowles Rd
Agawam, MA 01001-2908

800-518-3569

mguthrie@omginc.com

fastenmaster.com

DIVISION: 06 00 00 - WOOD, PLASTICS AND COMPOSITES
SECTION: 06 05 23 - Wood, Plastic, and Composite Fastenings

1 PRODUCT EVALUATED¹

- 1.1 FastenMaster® HeadLOK® Heavy Duty Wood Screw

2 APPLICABLE CODES AND STANDARDS^{2,3}

2.1 Codes

- 2.1.1 *IBC—15, 18, 21: International Building Code®*
- 2.1.2 *IRC—15, 18, 21: International Residential Code®*

2.2 Standards and Referenced Documents

- 2.2.1 *ANSI/AWC NDS: National Design Specification (NDS) for Wood Construction*
- 2.2.2 *ASTM A153: Standard Specification for Zinc Coating (Hot-Dip) on Iron and Steel Hardware*
- 2.2.3 *ASTM A510: Standard Specification for General Requirements for Wire Rods and Coarse Round Wire, Carbon Steel, and Alloy Steel*
- 2.2.4 *AWC TR 12: General Dowel Equations for Calculating Lateral Connection Values*

¹ For more information, visit drjcertification.org or call us at 608-310-6748.

² Unless otherwise noted, all references in this TER are from the 2021 version of the codes and the standards referenced therein. This material, design, or method of construction also complies with the 2000-2018 versions of the referenced codes and the standards referenced therein.

³ All terms defined in the applicable building codes are italicized.

3 PERFORMANCE EVALUATION

- 3.1 HeadLOK® fasteners were evaluated as an alternative means of attaching wood studs to the top and bottom plates to provide uplift resistance, thereby establishing a wall top plate to bottom plate continuous load path for code compliance.^{4,5}
 - 3.1.1 The withdrawal and head pull through strength of the HeadLOK® fasteners were evaluated as an alternative to toenail connections, uplift clips/straps, or the combined shear/uplift capacity of oriented strand board (uplift) loaded applications.
- 3.2 Any code compliance issues not specifically addressed in this section are outside the scope of this TER.
- 3.3 Any engineering evaluation conducted for this TER was performed within DrJ's ANAB accredited ICS code scope and/or the defined professional engineering scope of work on the dates provided herein.

4 PRODUCT DESCRIPTION AND MATERIALS

- 4.1 HeadLOK® fasteners (Figure 1) are manufactured of 1022 carbon steel or 10B21 wire conforming to *ASTM A510*.



FIGURE 1. HEADLOK® FASTENER

- 4.2 HeadLOK® fasteners are manufactured using a standard cold-formed process followed by a heat-treating process.
- 4.3 HeadLOK® fasteners are manufactured under in-plant quality control procedures. These procedures are audited through an inspection process performed by an approved agency.
- 4.4 Fasteners are approved for use in interior and exterior conditions and in chemically treated or untreated lumber.
 - 4.4.1 The proprietary coating has been tested and found to exceed the protection provided by code-approved hot-dipped galvanized coatings meeting *ASTM A153 (IBC Section 2304.10.6⁶ and IRC Section R317.3)*, allowing for its use in alkaline copper quaternary (ACQ) pressure treated wood.
 - 4.4.2 Fasteners are approved for use in fire-retardant-treated lumber, provided the conditions set forth by the fire-retardant-treated lumber manufacturer are met, including appropriate strength reductions.
- 4.5 The fasteners evaluated in this report are designated in Table 1.

TABLE 1. FASTENER DESIGNATIONS¹

| Product Name | Fastener Designation | Overall Length (in) | Thread Length (in) |
|-----------------|----------------------|---------------------|--------------------|
| HeadLOK® 4 1/2" | FMHLGM412 | 4 1/2 | 2 |
| HeadLOK® 6" | FMHLGM006 | 6 | 2 |

SI: 1 in = 25.4 mm

1. Fastener designations are found on the product packaging. Individual fasteners may be marked according to Table 1.

⁴ The *IRC Section R301.1* states, Application....The construction of buildings and structures in accordance with the provisions of this code shall result in a system that provides a complete load path that meets all requirements for the transfer of all loads from their point of origin through the load-resisting elements to the foundation. Section.R301.2.1 further states, Wind design criteria.... A continuous load path shall be provided to transmit the applicable uplift forces in Section R802.11.1 from the roof assembly to the foundation. See *IBC Section 1604.4*.

⁵ For joist/rafter and truss to top plate connection, see *TER 1105-02*.

⁶ 2018 *IBC Section 2304.10.5*



5 APPLICATIONS

- 5.1 HeadLOK® fasteners are used to attach minimum 3½" wide wood studs to wood top and bottom plates of shear wall assemblies that meet the requirements of IBC Section 2308 or IRC Section R602. These fasteners provide resistance to uplift loads due to wind negative pressure applied from the framing above lifting up on the top plate of the wall.
- 5.1.1 See Table 2 for the HeadLOK® allowable design values.
- 5.1.2 See Section 6 for installation requirements.
- 5.2 *Design Concepts and Allowable Design Loads*
- 5.2.1 Allowable design loads for uplift are provided in Table 2. This table lists allowable design loads based on penetration into the stud, number of fasteners used and framing member spacing applicable to fasteners installed in accordance with the procedures described in Section 6.
- 5.2.2 Where the application exceeds the limitations set forth herein, design shall be permitted in accordance with accepted engineering procedures, experience, and technical judgment.

TABLE 2. ALLOWABLE DESIGN LOAD IN UPLIFT^{1,2,3,4}

| Fastener Designation | Minimum Thread Length into End of Stud ⁵ (in) | Number of Fasteners | Allowable Design Uplift for Designated Stud Spacing (plf) | | | | |
|---|--|---------------------|---|----------|----------|----------|----------|
| | | | 12" o.c. | 16" o.c. | 24" o.c. | 32" o.c. | 48" o.c. |
| HeadLOK® 4½" with double plate | 1.5 | 1 | 640 | 480 | 320 | 240 | 160 |
| | | 2 | 1280 | 960 | 640 | 480 | 320 |
| HeadLOK® 4½" with single plate | 2 | 1 | 855 | 640 | 425 | 320 | 215 |
| HeadLOK® 6" with single or double plate | | 2 | 1710 | 1280 | 850 | 640 | 430 |

SI: 1 in = 25.4 mm, 1 psf = 0.048 kPa

1. Wood studs and top plate members shall be a minimum of 2" nominal thickness and have a minimum specific gravity of not less than 0.42.
2. Structural composite lumber (SCL) may be used, provided the specific gravity is equal to or greater than 0.42. Refer to product information from the SCL manufacturer.
3. Tabulated loads based on testing. Uplift load values have been adjusted from the test data conservatively.
4. Table design capacities assume a load duration of 1.6. Allowable uplift for other load durations shall be adjusted accordingly (e.g., for a load duration of 1.33, and a fastener spacing of 16", the allowable uplift would be 480 plf from the table divided by 1.6, and the result multiplied by 1.33 = 400 plf).
5. The minimum penetration shown is required to achieve the stated uplift capacities.

6 INSTALLATION

- 6.1 Installation shall comply with the manufacturer's installation instructions and this TER. In the event of a conflict between the manufacturer's installation instructions and this TER, the more restrictive shall govern.
- 6.2 Select the proper number and length of HeadLOK® screws based on the uplift loads and allowable HeadLOK® resistant loads from Table 2.
- 6.3 Installation Procedure
- 6.3.1 Use a ½" low RPM/high torque drill to drive the fastener to about 75 ft.-lbs.

6.3.2 Draw HeadLOK® up tight to the face of the plate, as shown in Figure 2 and Figure 3.

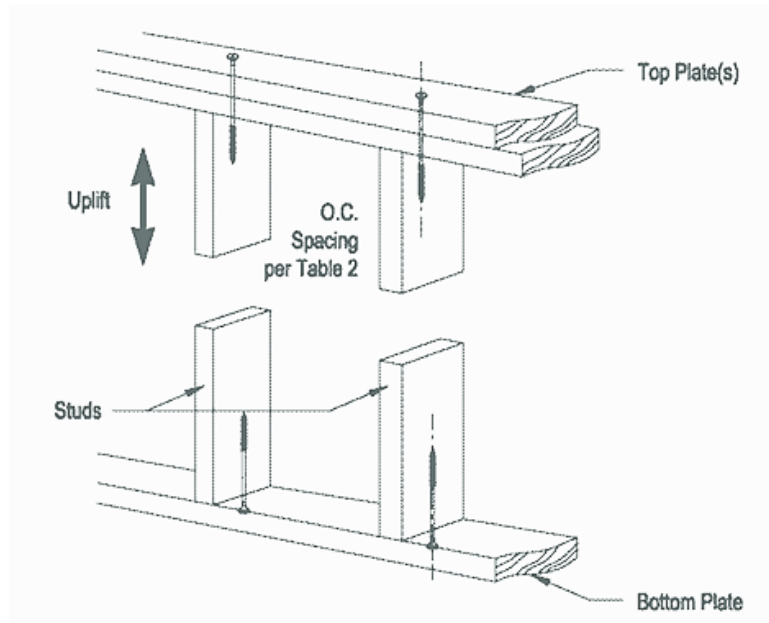

FIGURE 2. INSTALLATION OF ONE (1) HEADLOK® INTO DOUBLE TOP PLATE & SINGLE BOTTOM PLATE (NOTE: SIMILAR INSTALLATION WOULD BE USED FOR A SINGLE TOP PLATE AND/OR A DOUBLE BOTTOM PLATE.)

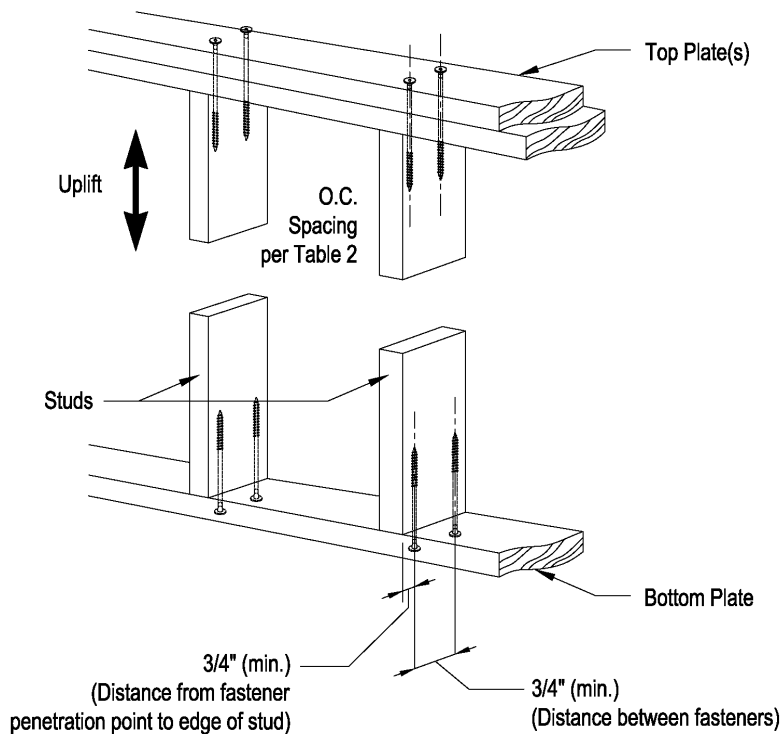

FIGURE 3. INSTALLATION OF TWO (2) HEADLOK® INTO DOUBLE TOP PLATE & SINGLE BOTTOM PLATE (NOTE: SIMILAR INSTALLATION WOULD BE USED FOR A SINGLE TOP PLATE AND/OR A DOUBLE BOTTOM PLATE.)

6.3.2.1 Do not over tighten (free spin) the screw.

6.3.2.2 If the fastener spins freely upon tightening, install one (1) additional HeadLOK® fastener a minimum of 3/4" from the ineffective fastener.

6.4 Installation Issues and Solutions

- 6.4.1 If a fastener protrudes outside of the stud prior to engagement into the stud such that threads are visible, install one (1) additional HeadLOK® fastener a minimum of ¾" from the misaligned fastener (see Figure 2).
 - 6.4.1.1 If no fastener threads are visible but the unthreaded shank is visible, the fastener can remain in place and the values in Table 2 may still be used.
- 6.4.2 If a fastener splits the stud, install one (1) additional HeadLOK® fastener a minimum of ¾" from the original fastener, or remove the original fastener and reinstall it a minimum of ¾" from the original location.
- 6.4.3 For the repair scenarios described above, a maximum of three (3) fasteners per stud is allowed.

7 SUBSTANTIATING DATA

- 7.1 Testing has been performed under the supervision of a professional engineer and/or under the requirements of ISO/IEC 17025 as follows:
 - 7.1.1 Fastener testing for use as a truss hold-down
 - 7.1.2 Fastener testing for top plate to stud withdrawal
- 7.2 Information contained herein is the result of testing and/or data analysis by sources which conform to IBC Section 1703 and/or professional engineering regulations. DrJ relies upon accurate data to perform its ISO/IEC 17065 evaluations.
- 7.3 Where appropriate, DrJ's analysis is based on provisions that have been codified into law through state or local adoption of codes and standards. The providers of the codes and standards are legally responsible for their content. DrJ analysis may use code-adopted provisions as a control sample. A control sample versus a test sample establishes a product as being equivalent to that prescribed in this code in quality, strength, effectiveness, fire resistance, durability, and safety. Where the accuracy of the provisions provided herein is reliant upon the published properties of materials, DrJ relies upon the grade mark, grade stamp, mill certificate, and/or test data provided by material suppliers to be minimum properties. DrJ analysis relies upon these properties to be accurate.

8 FINDINGS

- 8.1 When used and installed in accordance with this TER and the manufacturer's installation instructions, the product(s) listed in Section 1.1 are approved for the following:
 - 8.1.1 To provide resistance to uplift loads due to wind negative pressure applied from the framing above lifting up on the top plate of the wall, per Table 2
 - 8.1.2 To provide resistance to uplift loads due to wind negative pressure applied from the framing above at the stud to bottom plate interface, per Table 2
- 8.2 For joist/rafter and truss to top plate connection, see TER 1105-02: Use of FastenMaster® TimberLOK® Fasteners to Provide Uplift & Lateral Resistance to Trusses & Rafters Attached to the Tops of Walls.
- 8.3 Building codes require data from valid research reports be obtained from approved sources (i.e., licensed registered design professionals [RDPs]).
 - 8.3.1 Building official approval of a licensed RDP is performed by verifying the RDP and/or their business entity is listed by the licensing board of the relevant jurisdiction.
- 8.4 Agencies who are accredited through ISO/IEC 17065 have met the code requirements for approval by the building official. DrJ is an ISO/IEC 17065 ANAB-Accredited Product Certification Body – Accreditation #1131 and employs RDPs.
- 8.5 Through ANAB accreditation and the IAF MLA, DrJ certification can be used to obtain product approval in any jurisdiction or country that has IAF MLA Members & Signatories to meet the Purpose of the MLA – “certified once, accepted everywhere.”

8.6 IBC Section 104.11 (IRC Section R104.11 and IFC Section 104.10⁷ are similar) states:

104.11 Alternative materials, design and methods of construction and equipment. The provisions of this code are not intended to prevent the installation of any material or to prohibit any design or method of construction not specifically prescribed by this code...Where the alternative material, design or method of construction is not *approved*, the *building official* shall respond in writing, stating the reasons the alternative was not *approved*.

9 CONDITIONS OF USE

- 9.1 The HeadLOK® fasteners covered in this TER shall be installed in accordance with this report and the manufacturer's installation instructions.
- 9.2 For conditions not covered in this TER, connections shall be designed in accordance with generally accepted engineering practice.
- 9.3 Where required by the *building official*, also known as the authority having jurisdiction (AHJ) in which the project is to be constructed, this TER and the installation instructions shall be submitted at the time of *permit* application.
- 9.4 Any generally accepted engineering calculations needed to show compliance with this TER shall be submitted to the AHJ for review and approval.
- 9.5 Design loads shall be determined in accordance with the building code adopted by the jurisdiction in which the project is to be constructed and/or by the building designer (e.g., owner or RDP).
- 9.6 At a minimum, this product shall be installed per Section 6 of this TER.
- 9.7 This product has an internal quality control program and a third-party quality assurance program in accordance with IBC Section 104.4 and Section 110.4 and IRC Section R104.4 and Section R109.2.
- 9.8 The actual design, suitability, and use of this TER, for any particular building, is the responsibility of the owner or the owner's authorized agent.
- 9.9 This TER shall be reviewed for code compliance by the AHJ in concert with IBC Section 104.
- 9.10 The implementation of this TER for this product is dependent on the design, quality control, third-party quality assurance, proper implementation of installation instructions, inspections required by IBC Section 110.3, and any other code or regulatory requirements that may apply.

10 IDENTIFICATION

- 10.1 FastenMaster® HeadLOK® screws described in this TER are identified by a label on the board or packaging material bearing the manufacturer's name, product name, label of the third-party inspection agency, TER number and other information to confirm code compliance.
- 10.2 Additional technical information can be found at fastenmaster.com.

11 REVIEW SCHEDULE

- 11.1 This TER is subject to periodic review and revision. For the most recent version, visit drjcertification.org.
- 11.2 For information on the current status of this TER, contact DrJ Certification.

⁷ 2018 IFC Section 104.9